

Appendix I Responses to the External Peer Review of the Proposed Desalination Amendment

Appendix I Responses to the External Peer Review of the Proposed Desalination Amendment

Associated with the Draft Final Staff Report Including the Draft Final Substitute Environmental Documentation For the ~~Proposed~~ Draft Final Desalination Amendment

Peer reviewers are as follows:

- 1) Ben R. Hodges, Ph.D. (**BRH**)
Associate Professor, Environmental and Water Resource Engineering
Department of Civil, Architectural and Environmental Engineering
University of Texas at Austin ECJ 8.208
301 E. Dean Keeton Street
Austin, Texas 78712

Telephone: (512) 471-4730
Facsimile: (512) 471-0592
Email: Hodges@utexas.edu

- 2) Lisa A. Levin, Ph.D. (**LAL**)
Distinguished Professor
Integrative Oceanography Division
Scripps Institution of Oceanography
University of California San Diego
9500 Gilman Drive, #0218
La Jolla, CA 92093-0218

Telephone: (858) 534-3579
Facsimile: (858) 822-0562
Email: Llevin@ucsd.edu

- 3) E. Eric Adams, Ph.D., P.E. (**EEA**)
Senior Lecturer and Senior Research Engineer
Department of Civil and Environmental Engineering
Massachusetts Institute of Technology (MIT)
Room 48-216-B
15 Vassar Street
Cambridge, MA 02139

Telephone: (219)-253-6596
Email: eeadams@mit.edu

- 4) Bronwyn Gillanders, Ph.D. (**BG**)
Professor, Ecology and Evolutionary Biology
University of Adelaide
SA 5005
Australia

Telephone: 011-61-8-8313-6235
Facsimile: 011-61-8-8313-4364
Email: Bronwyn.gillanders@adelaide.edu.au

- 5) Robert Howarth, Ph.D. (**RH**)
Professor of Ecology and Environmental Biology
College of Agriculture and Life Sciences

Appendix I Responses to the External Peer Review of the Proposed Desalination Amendment

Cornell University E309 Corson Hall Ithica, N.Y. 14853

Telephone: (607) 255-6175
Facsimile: (607) 255-8088
Email: howarth@cornell.edu

- 6) Nathan Knott, Ph.D. **(NK)**
Research Scientist, Fisheries NSW, NSW Department of Primary Industries
Senior Fellow, School of Biological Sciences, University of Wollongong
P.O. Box 89
Huskisson NSW 2540

Telephone: 011-61-2-4428-3002
Facsimile: 011-61-2-4441-7756
Email: nathan.knott@dpi.nsw.gov.au

- 7) Scott A. Socolofsky, Ph.D. **(SAS)**
Associate Professor and Division Head
Coastal and Ocean Engineering Division
Zachary School of Engineering
Texas A & M University
CE/TTI 801B
College Station, TX 77843-3136

Telephone: 979-845-4517
Facsimile: 979-862-8162
Email: socolofs@tamu.edu

Contents

1. Ben R. Hodges, Ph.D. (BRH).....	3
2. Lisa A. Levin, Ph.D. (LAL).....	15
3. E. Eric Adams, Ph.D., P.E. (EEA)	35
4. Bronwyn Gillanders, Ph.D. (BG).....	43
5. Robert W. Howarth, Ph.D. (RWH).....	46
6. Nathan Knott, Ph.D. (NK).....	55
7. Scott A. Socolofsky, Ph.D. (SAS).....	64

Appendix I Responses to the External Peer Review of the Proposed Desalination Amendment

1. Ben R. Hodges, Ph.D. (BRH)

Summary

The starting point for this review are the conclusions in the “Description of Scientific Conclusions to be Addressed by Peer Reviewers,” which are:

1. *A receiving water salinity limit of two parts per thousand (ppt) above natural background salinity is protective of marine communities and beneficial uses.*
2. *A subsurface seawater intake will minimize impingement and entrainment of marine life.*
3. *A 0.5 mm, 0.75 mm, 1.0 mm, or other slot sized screens installed on surface water intake pipes reduces entrainment.*
4. *Multiport diffusers and commingling brine with other effluents can dilute brine discharge and provide protection to aquatic life.*
5. *The Area Production Forgone (APF) method using an Empirical Transport Model (ETM) can effectively calculate the mitigation area for a facility’s intakes.*

I have reviewed these as commensurate with my expertise. I have significant concerns over the validity of Conclusion 1 due to far field effects on dissolved oxygen with a negatively-buoyant plume. I believe Conclusion 1 needs to be reconsidered and its implementation in the WQCP requires significant revision. Conclusion 2 is true and does not engender any significant comments. Conclusion 3 is true, but it is not clear that specifying a mesh size is the best approach for regulation in an area that is still undergoing technological advances – particularly since the mesh has consequences for energy costs. It might be better to specify required maximum entrainment limits and a test system for new technologies. Conclusion 4 is well-founded, but its implementation in the WQCP raises some concerns for comingling systems that are not well balanced or when the comingling water is shut down. The concerns raised in Conclusion 1 apply to Conclusion 4 to the extent that a negatively-buoyant plume is developed. I do not have the expertise to make any comments on Conclusion 5. Specific details are provided in the sections below.

COMMENT BRH1

Comments on Conclusion 1 and its implementation in the WQCP

My opinion Conclusion 1, as written – “two parts per thousand (ppt) above natural background salinity *is* protective” – is not supported by the state-of-the-science, which merely indicates 2 ppt *might* be adequate for *some* brine discharges. Comprehensive in situ experiments to analyze benthic ecosystem functioning under a weak far-field salinity plume have not been conducted. Because such a plume can cause reduction in dissolved oxygen (DO) levels, the present state-of-the-science cannot support a clear near-field salinity limit that is protective in any absolute sense. Furthermore, the proposed changes to the Water Quality Control Plan (WQCP) reflect the *assumption* that 2 ppt is protective, which could allow brine discharges to cause significant ecological harm. Finally, the monitoring required in the WQCP is inadequate to detect some forms of ecological harm in the far field.

RESPONSE TO BRH1

Appendix I Responses to the External Peer Review of the Proposed Desalination Amendment

With regard to salinity, studies reviewed by the Expert Review Panel on Impacts and Effects of Brine Discharges (ERP I) described in the report titled “Management of Brine Discharges to Coastal Waters Recommendations of a Science Advisory Panel” SCCWRP Technical Report 694, March 2012

(http://www.waterboards.ca.gov/water_issues/programs/ocean/desalination/docs/dpr.pdf)

coupled with the Hyper-Salinity Toxicity Thresholds for Nine California Ocean Plan Toxicity Test Protocols performed by the University of California, Davis

(http://www.waterboards.ca.gov/water_issues/programs/ocean/desalination/docs/salttoxfr08012.pdf) suggest that 2 ppts would protect most organisms from salinity related

effects. Note that a desalination facility would also have to meet all existing applicable requirements of the California Ocean Plan (Ocean Plan) in addition to those proposed in this amendment. The Ocean Plan includes a narrative objective that prevents degradation of marine communities and as a result, any change to biological communities caused by a brine plume outside the brine mixing zone will represent a violation of this narrative objective. In regards to hypoxia, chapters III.L.2.c (4) and III.L.4.a of the proposed Desalination Amendment were amended to address this comment by adding the requirement to consider the effects of hypoxia in the design and to monitor for potential impacts associated with hypoxia. Associated monitoring would consist of dissolved oxygen and benthic community health.

COMMENT BRH2

Overview of problems

Conclusion 1 is too broadly stated, and as such is simply is not supported by the present state-of-the-science or by the Jenkins et al (2012) report of the Science Advisory Panel on Management of Brine Discharges to Coastal Waters. Indeed, Jenkins et al (2012) does not make the sweeping statement that such a limit “is protective,” but instead provides a number of caveats as to the design and placement of discharges that is necessary for protection. Their conclusion would be better condensed as *A receiving water salinity limit of two parts per thousand (ppt) above natural background salinity should be protective of marine communities and beneficial uses for a well-designed and well-placed brine discharge.* The differences between the statement “is protective” and the caveats above are important because: (1) California often plays the role of first regulator or as an exemplar for critical environmental issues, and a broad misstatement of what is protective could have long-term consequences throughout the nation and the world; (2) the proposed changes to the California WQCP should specifically address the caveats in the design and siting of the brine discharge rather than assuming that 2 ppt is protective for all cases. Changing Conclusion 1 to reflect the caveats discussed in Jenkins et al (2012) will require rethinking the approach for approval and monitoring of negatively-buoyant brine discharges. Whether or not a brine plume can cause hypoxia at the sediment-water interface in the plume far field should be evaluated in brine disposal design, siting, and monitoring program.

RESPONSE TO BRH2

The proposed Desalination Amendment requires that an owner or operator site and design the facility’s intake and outfalls structures to maximize dilution and minimize impacts to all forms of marine life as described in chapter III.L.2. a, b, and c of the

Appendix I Responses to the External Peer Review of the Proposed Desalination Amendment

proposed Desalination Amendment. The proposed Desalination Amendment does not rely singularly on the receiving water limit but rather employs the receiving water limit as a backstop. A properly designed facility employing a diffuser could meet the receiving water limit with little chance of exceeding the limit. As described in response to comment BRH1, both the review described in the report titled “Management of Brine Discharges to Coastal Waters Recommendations of a Science Advisory Panel” and the Hyper-Salinity Toxicity Thresholds for Nine California Ocean Plan Toxicity Test Protocols described above suggest that 2 ppt would protect most organisms from salinity related effects. As described in Section 8.7.1 of the Staff Report with SED, this study evaluated the nine species through multiple endpoints including growth reproduction and mortality.

Furthermore, the Ocean Plan already includes a biological narrative objective that prevents degradation of marine communities and requires all dischargers to monitor the health of the benthic community in response. Many species making up the benthic community are relatively sessile and as a result cannot escape to better or un-impacted habitats. Any impact cause by the discharge outside the zone of initial dilution or brine mixing zone will be considered a permit violation. It is important to consider the variability of salinity in receiving waters; Section 8.7.2 of the Staff Report describes the variability of ocean salinity and presents graphs illustrating temporal variability in one northern California site (Crescent City) and one southern California (Huntington Beach) over a period of twenty years. This variability ranged from 35.6 to 13.6 ppt off Crescent City and from 31.06 ppt to 34.3 ppt off Huntington Beach which suggests that salinity is not constant and that many organisms have some ability for osmoregulation. In regards to the last comment requesting consideration of impacts associated with hypoxia please see response to comment BRH1.

COMMENT BRH3

Elaboration: Is 2 ppt proven protective? Why not?

From an engineering standpoint, the 2 ppt threshold seems both reasonable and achievable. From a laboratory standpoint, the 2 ppt threshold appears to prevent sever toxic effects of salinity. However, convincing field monitoring of existing brine discharges to prove a 2 ppt threshold “is protective” simply do not exist. Jenkins et al (2012) *recommends* the use of 5% of natural salinity variation – or about 1.7 ppt for coastal water – based on a thorough review of the state-of-the-science. However, they note that the state-of-the-science is actually rather sketchy and incomplete. The best that can be said is that *a 2 ppt threshold appears satisfactory from a toxicity viewpoint, but that cannot be taken to imply a threshold that is protective of an ecosystem.* The underlying problem is that salinity, unlike low-concentration dissolved toxics (such as metals), affects the local flow field by stratification, which reduces mixing and can lead to reduced dissolved oxygen (DO) levels in the benthic layer, with the follow on effect of stressing the ecosystem. Thus, the regulatory methods that are typically used to evaluate effects of dissolved toxics must be supplemented by approaches that consider the physical salinity effects on the local flow field and stratification, as well as how stratification and sediment oxygen demand (SOD) affect the dissolved oxygen (DO) levels in the plume. A simple salinity

Appendix I Responses to the External Peer Review of the Proposed Desalination Amendment

standard without an additional DO or mixing rate standard for negatively buoyant plumes cannot be considered protective. It should be noted that DO problems have not been observed in existing brine discharges, but this appears to be because DO has not been routinely monitored in the far field plume where problems might occur. That is, DO will not likely be a problem in the near field or regulatory mixing zone where monitoring is typically undertaken. Furthermore, unlike positively buoyant wastewater discharges, negatively buoyant brine discharges have not been well studied, and the State of California should carefully consider the relative paucity of existing research in revising the WQCP so that approvals do not move ahead of the state-of-the-science.

RESPONSE TO BRH3

The approach used here to evaluate toxicological thresholds for salinity is similar to those methods used to develop water quality objectives. However, because few data sets were available, the State Water Board contracted with UC Davis to perform additional testing and analysis. The proposed Desalination Amendment requires careful consideration of the siting and design of a facility in order to minimize impacts to marine life as described in chapters III.L.2. a, b, and c. In addition, chapters III.L.2.c (4) and III.L.4.a of the proposed Desalination Amendment were amended adding requirement to consider the effects of hypoxia in the design and to monitor for potential impacts associated with hypoxia. As described in BRH2, monitoring benthic community health will be used to ensure that the discharge is not causing impacts to marine life. If sensitive habitats are located nearby the facility, then the intake and outfall structure may need to be located further away to ensure these habitats are unaffected.

COMMENT BRH4

What happens to dense plumes beyond the regulatory mixing zone?

Negatively buoyant brine plumes outside the regulatory-defined mixing zone cannot be assumed to simply disappear without consequences. The assumption that the regulatory mixing zone approach is adequate appears to be a hold-over from prior regulation of positively-buoyant plumes. Note that Jenkins et al (2012) goes to some length to explain the effects of negatively buoyant plumes and considerations that should be included in the regulatory scheme. It does not appear that their concerns were adequately implemented in the WQCP.

The key difference between a positively buoyant plume at the surface and a negatively buoyant plume at the bottom is that the former is subject to strong mixing energetics from wind and breaking waves, where the latter only mixes due to its own movement down the slope. These differences are reflected in concept of “entrainment.” Active turbulence within the plume itself will entrain ambient water, hence diluting the difference between the plume and ambient. With this dilution, DO from the ambient water is mixed with the plume water. For buoyant surface plumes, the active turbulence from wind and waves ensures rapid entrainment of the ambient and DO replenishment. In contrast, a dense brine plume has only its bottom-generated (shear) turbulence to entrain ambient water, so its dilution rate and DO resupply rate are much smaller. Furthermore, to the extent that the plume does have entrainment and mixing, this slows the plume and weakens the entrainment rate. Note that turbulence from the ambient acts as detrainment – reducing the plume thickness – but has minor impact on entrainment into a plume. That is, detrainment to the ambient slowly makes the plume thinner, but does not dilute

Appendix I Responses to the External Peer Review of the Proposed Desalination Amendment

the plume and hence does not resupply DO through the plume to the sediments. An example might make this issue clearer. For a dense brine plume, the entrainment rate is a function of the slope and the salinity difference (e.g. Dallimore et al 2001, Bo Pedersen 1986). For slopes on the order of 10^{-3} to 10^{-4} with small salinity differences the entrainment rate can be expected to be on the order of 10^{-4} to 10^{-5} . Using the Dallimore et al (2001) approach, 1000 m downstream from the 2 ppt threshold point in a plume of 1 m thickness the salinity for a steeper slope (10^{-3}) would be expected to be near ambient –i.e. complete mixing (the plume has fully entrained the ambient); but the less steep slope 4×10^{-4} would only see the salinity increment reduced by about 10% (0.2 ppt). It follows that the length scale for full mixing of the plume on a 10^{-4} slope is on the order of 10 km. For plume velocities on the order 0.01 to 0.1 m/s, the implied transit time from the 2 ppt threshold to the edge of the plume is 1 to 10 days. During that transit time, if the sediment oxygen demand (SOD) is greater than the DO replenishment rate due to entrainment, the plume will slowly lose DO, which can result in hypoxia in the far field of the plume. Jenkins et al (2012) discusses these effects and refers the reader to Hodges et al (2011) for further details. Note that close to the regulatory mixing point, with the strongest stratification of the plume, there will actually be higher DO levels than where the plume stratification is weaker but the transit time is longer. Thus, modeling and monitoring to the regulatory mixing point is insufficient. Some combination of modeling and monitoring of far field conditions is necessary to predict and ensure that far field hypoxia is not an issue for negatively buoyant plumes. Because of the general characteristics of flow along the California coastline, it is likely the most desalination plants will not have any trouble preventing development of hypoxia in the far field plume. However, there are likely to be locations where a poorly sited or poorly designed discharge could result in an extensive hypoxic far field. Because the science on this issue is relatively new, it is recommended that California take the lead on developing regulatory modeling and monitoring strategies that address this issue.

RESPONSE TO BR4

As written, the proposed Desalination Amendment requires that the salinity be reduced to within 2 ppt within 100 meters in all directions from the point(s) of discharge. Aquatic life degradation cannot occur beyond that distance. We agree that there are not likely to be many of these situations; however, in the event that monitoring of the receiving water indicates that the receiving water limit is exceeded or aquatic life is degraded beyond the brine mixing zone, the applicable regional water board would take the appropriate enforcement action. If an owner or operator is unwilling to take the necessary corrective action, the regional water board has the authority to shut down a non-compliant facility.

COMMENT BRH5

Implementation of discharge standards in 2014 Ocean WQCP

The Jenkins et al (2012) report outlined a 3-pronged approach to regulation (see their Chapter 7) that separately addresses the surf zone, inner shelf, and deep water disposal. These distinctions were not implemented in the WQCP. Recommend the State reconsider this issue and revise the WQCP to implement the strategies of Jenkins et al (2012). In particular, deposition in the surf zone might have less stringent considerations for negatively buoyant plumes due to the strong mixing action of breaking waves that can influence bottom mixing in shallow water. Specific rules for modeling and monitoring in the WQCP should take into account

Appendix I Responses to the External Peer Review of the Proposed Desalination Amendment

the differences between these zones.

RESPONSE TO BRH5

Disagree. Some surf zone discharges are simply pushed back onshore and move laterally up or down coast with limited mixing which could affect California grunion (*Leuresthes tenuis*), sand crabs, and other seashore marine life. Commingling brine with wastewater is the preferred brine disposal technology. Using a diffuser to achieve rapid initial mixing is the next preferred approach when wastewater is unavailable. Diffusers can be constructed offshore and should be sited away from rock reefs and other sensitive habitats when feasible. The proposed Desalination Amendment includes a restricted brine mixing zone to be no larger than 100 meters horizontally from the point(s) of discharge, and should be met throughout the water column, which provides site-specific flexibility but is also an equitable approach.

COMMENT BRH6

Comments on the WQCP by section

II.A.3. – Compliance requires only sampling within the initial dilution field, which neglects far field effects of salinity stratification on DO.

RESPONSE TO BRH6

This sentence requires sampling be to be performed in the plume but beyond the brine mixing zone. As stated above, dissolved oxygen is not directly regulated under the proposed Desalination Amendment. However, other existing provisions in the Ocean Plan require that aquatic life is not to be degraded as a result of the discharge and monitoring is required to demonstrate compliance with that requirement. As described previously, chapters III.L.2.c (4) and III.L.4.a. of the proposed Desalination Amendment were amended adding requirement to consider the effects of hypoxia in the design and to monitor for potential impacts associated with hypoxia. These changes would require a proponent to minimize the potential for hypoxia by design of the facility and outfall, and to perform monitoring of dissolved oxygen and benthic community health to demonstrate that hypoxia does not occur as a result of the discharge.

COMMENT BRH7

II.C and II.D. – Chemical characteristics for DO (II.D.1) are focused only on oxygen demand within the waste (which is negligible for brine), and there is no consideration of the reduction of DO due to combination of physics of stratification and mixing (arguably part of II.C) and the interaction with SOD (arguably part of II.D).

RESPONSE TO BRH7

Correct. The objective described in chapter II.E.1. of the Ocean Plan is the backstop that prevents degradation of marine life as a result of ocean discharges, including brine discharges from desalination facilities.

COMMENT BRH8

II.D.7. b. – Table 1. There is no water quality objective for minimum DO (or maximum DO deficit) in the far field plume.

RESPONSE TO BRH8

Appendix I Responses to the External Peer Review of the Proposed Desalination Amendment

Correct. Please see response to BRH7.

COMMENT BRH9

III.A.2.– Recommend a general provision that “Waste discharged to the ocean must not result in sustained low dissolved oxygen conditions” with additional definitions for the maximum allowable time interval for low DO and the minimum allowable low DO limit.

RESPONSE TO BRH9

Agree that a general provision for DO would be beneficial, but developing new water quality objectives would require additional time and resources, and is out of the scope of the proposed Desalination Amendment. The proposed changes included chapters III.L.2.c (4) and III.L.4.a of the proposed Desalination Amendment addressing hypoxia, coupled with existing Ocean Plan requirements will prevent low DO from negatively affecting marine life.

COMMENT BRH10

Benthic ecologists should be consulted to set these values. To preserve the meaning of “above a water quality limit” elsewhere in the plan, it may be necessary to write a regulatory limit for a DO deficit (i.e. the excursion below a natural level that cannot be exceeded).

RESPONSE TO BRH10

Please see response to BRH9. The existing Ocean Plan requires dischargers to monitor the benthic community. The proposed Desalination Amendment will specifically require desalination facilities to monitor the health of the benthic community and for hypoxia to ensure that degradation is not occurring as the result of brine discharges.

COMMENT BRH11

III.L.2.a.(2) and elsewhere – The phrase “to minimize intake and mortality,” which is used in a number of places, is troublesome and potentially limiting when considering the potential stressor effects of chronic low DO on the benthos, which can result from a negatively buoyant brine discharge. Such effects may not be directly attributable to increased mortality, but can have a significant impact on the overall health, sustainability, and habitat suitability of an ecosystem. Recommend consulting a benthic ecologist on an improved way to write a general statement of the regulatory purpose.

RESPONSE TO BRH11

The phrase “minimize intake and mortality” is included throughout chapter III.L.2. of the proposed Desalination Amendment because it is consistent with the statutory language that gives the Water Boards the authority to regulate seawater intakes at desalination facilities (Wat. Code § 13142.5(b)). However, the consideration of intake and mortality of all forms of marine life is not the requirement addressing the potential effects of chronic low DO in the effluent. The existing objective described in chapter II.E.1. of the Ocean Plan is the backstop that prevents degradation of marine life as a result of the discharge. Please see response to BRH9 above.

COMMENT BRH12

III.L.2.c.(4) – This section appears to require a positively-buoyant plume, however this

Appendix I Responses to the External Peer Review of the Proposed Desalination Amendment

requirement is at odds with allowing a 2 ppt increase in salinity. A 2 ppt increase in salinity will result in a dense negatively-buoyant plume. Recommend rewriting this section with something like “Design the outfall such that negatively buoyant plumes do not result in DO deficit levels below the Table 1 standard in the plume far field.” There will be a need to define a regulatory far field condition and provide a DO deficit standard as noted for comments on II.D.7.b and III.A.2 above.

RESPONSE TO BRH12

Chapter III.L.2.c.(4) of the proposed Desalination Amendment has been amended to require that a proponent design an outfall in such a way that impacts associated with salinity or hypoxia do not occur beyond the brine mixing zone. Please see response to BRH9 above, and BRH13 below.

COMMENT BRH13

III.L.2.c.(4) – Using anoxia (zero oxygen) as a limiting condition is not protective of the marine ecosystem. Sustained hypoxia (low oxygen) is known to be detrimental and can be consequence of only a weak negatively buoyant plume.

RESPONSE TO BRH13

Agree and have replaced the term “anoxic” with “hypoxic” in chapters III.L.2.c.(4) and III.L.4.a of the proposed Desalination Amendment.

COMMENT BRH14

III.L.2.d.(2) – Recommend a subparagraph specifically addressing far-field DO considerations for brine discharge technology.

RESPONSE TO BRH14

The requirements in the proposed Desalination Amendment will be coupled with existing Ocean Plan requirements in permits issues to desalination facilities. These combined requirements are expected to limit any impacts to marine life outside the brine mixing zone. Consequently, there is no need to consider far-field effects. If there are impacts outside the brine mixing zone caused by the discharge of brine, the facility operators will have to implement corrective actions to ensure that those impacts are eliminated or minimized and mitigated.

COMMENT BRH15

III.L.2.d.(2)(b) – The requirement that multiport diffusers “be engineered to maximize dilution and minimize the brine mixing zone” are inherently at odds. The diffusers cannot significantly change the overall flux rate associated with the ocean water moving through the brine mixing zone, therefore maximizing dilution inherently requires maximizing the size of the brine mixing zone for a given throughput of ambient water.

Recommend that this requirement simply be stated that multiport diffusers be designed to maximize the near-field dilution.

RESPONSE TO BRH15

Comment noted and no change was made because the meaning in the proposed Desalination Amendment and the suggested language is similar. The statement is included to ensure that the outfall is engineered to achieve rapid turbulent mixing.

Appendix I Responses to the External Peer Review of the Proposed Desalination Amendment

Properly designed multiport diffusers can rapidly mix brine with ambient waters within a relatively small area. Rapid mixing and dilution in the near-field environment reduces potential for far-field impacts.

COMMENT BRH16

III.L.2.e.(1) – The Marine Life Mortality Report does not require a report on far-field effects of salinities, which may be less than 2 ppt but still cause stratification, reduced mixing, low benthic DO, and habitat loss. The areas impacted, and the time scales/conditions under which such impacts occur during operation should be reported. This issue is critical because subparagraph III.L.2.e(3)(b).iii only requires mitigation for mortality that is reported in the Marine Life Mortality Report. It is possible that the impact area of low DO is much larger than the regulatory mixing zone.

RESPONSE TO BRH16

Disagree. The Marine Life Mortality Report requires an assessment of all mortality associated with the intake of seawater, discharge of brine, construction of a facility, and any other marine life mortality associated with a desalination facility. Chapter III.L.2.a(1) of the proposed Desalination Amendment was revised to include that “The regional water board in consultation with the State Water Board staff may require an owner or operator to provide additional studies or information needed, including any information necessary to identify and assess other potential sources of mortality to all forms of marine life.”

Furthermore, there is a requirement that an owner or operator fully mitigate for mortality of all forms of marine life, which would include any far-field impacts.

COMMENT BRH17

III.L.3.b. – Recommend that the receiving water limitation for salinity should be rewritten as the lower of 2 ppt or a salinity increment that maintains the far field DO deficit above the regulatory criteria of Table 1 (see comments on II.D.7.b and III.A.2 and III.L.2.c.(4) above).

RESPONSE TO BRH17

Disagree. The proposed Desalination Amendment coupled with existing requirements in the existing Ocean Plan are adequate to protect marine life from the effects associated with salinity and hypoxia.

COMMENT BRH18

III.L.3.c – The alternative salinity receiving water limitation needs to be rewritten to include far field DO considerations. The present wording is focused only on the toxicity of salinity and not on its impact on stratification and benthic DO.

RESPONSE TO BRH18.

Disagree. Please see response to BRH17 above.

COMMENT BRH19

III.L.4 – Monitoring programs should be modified to specifically include far field monitoring for salinity, temperature, and DO.

RESPONSE TO BRH19

Chapter III.L.4.a and III.L.2.c.(4) of the proposed Desalination Amendment were amended

Appendix I Responses to the External Peer Review of the Proposed Desalination Amendment

to address monitoring for potential impacts associated with hypoxia. The type of monitoring would consist of dissolved oxygen, benthic community health, and any other monitoring deemed appropriate by the regional water boards.

COMMENT BRH20

Comments on Conclusion 2 and its implementation in the WQCP

I have reviewed the standards and scientific justifications for the subsurface seawater intakes. Although this is not my specific research area, I have a general expertise in environmental fluid mechanics that allows me to judge the physical basis of the conclusions (albeit not the marine life aspects).

To be pedantic, the statement in Conclusion 2 that “subsurface seawater intakes will minimize impingement and entrainment of marine life,” is not precisely correct. It would be better to state that such methods will *reduce* impingement and entrainment relative to surface intakes. It is not clear that science supports these as the “minimum.” I cannot find any problems with either the scientific basis for requiring subsurface seawater intakes or the implementation program in the proposed regulations.

RESPONSE TO BRH20

Comment noted.

COMMENT BRH21

Comments on Conclusion 3 and its implementation in the WQCP

I have reviewed the standards and scientific justifications for the specification of screen sizes. Although this is not my specific research area, I have a general expertise in environmental fluid mechanics that allows me to judge the physical basis of the conclusions (albeit not the marine life aspects).

Although Conclusion 3 is well-founded, there is an open question as to whether 0.5 mm, 0.75 mm, 1.0 mm, or other slot sized should be specified for surface water intake pipes to reduce entrainment of marine life. I have not been able to reach a clear conclusion myself from reading the background literature. However, it is not clear to me that specifying a fixed mesh is necessarily the best regulatory approach. The mesh size affects energy use, and hence costs, and there are clearly a wide variety of different methods that are both feasible and effective. I support the regulations, III.L.2.d.(1)(c)iii, that allow the owner/operator to select equivalent alternative technologies that have the same benefit. It would likely be beneficial to develop a specific set of standards for entrainment that are not linked to a mesh size; that is, rather than comparing an alternative to the performance of a given mesh, all system should be compared to a desired set of entrainment limits. By setting regulations based on clear limits rather than mesh size, the state will remove the difficulty of determining what is “equivalent” to the specified mesh.

RESPONSE TO BRH21

Disagree. It is important to establish a standard by which all surface water intakes can meet to minimize potential impacts from surface water intakes. The data presented in section 8.3.1.2.3 and Appendix D of the Staff Report with SED indicates that reducing screen size can reduce entrainment.

Appendix I Responses to the External Peer Review of the Proposed Desalination Amendment

COMMENT BRH22

Comments on Conclusion 4 and its implementation in the WQCP

I have reviewed the standards and scientific justifications for the conclusion that multiport diffusers and comingling are effective at diluting the brine discharge and hence provide protection for aquatic life. This conclusion is correct, with the caveats discussed associated with Conclusion 1 – i.e. residual density anomalies resulting in a negatively buoyant plume may still cause harm in the far field, even though immediate toxic effects in the near field are ameliorated.

RESPONSE TO BRH22

Comment noted. Please see response to comment BRH14.

COMMENT BRH23

The implementation of these ideas in III.L.2.d.(2)(a) could be made clearer. The assumption inherent in the comingling strategy is that the wastewater (low salinity) mixing with the brine (high salinity) results in a positively-buoyant discharge; i.e. the resulting salinity is *always* less than ambient. However, this result will actually depend on the volume flow rates of brine and the comingled source. Where comingling does not always produce a positively buoyant plume, then multiport diffusers will necessarily be required. Recommend this section of the regulations be rewritten so that the preferred technology is comingling with a sufficient flow rate to provide a positively-buoyant plume under all desalination plant operating conditions. This regulation would imply that a shutdown of the comingled water source requires shut down of the desalination plant.

RESPONSE TO BRH23

Chapter III.L.2.d.(2) of the proposed Desalination Amendment was revised to state that the wastewater must provide adequate dilution to ensure salinity of the commingled discharge is less than or equal to the natural background salinity, or the commingled discharge shall be discharged through multiport diffusers. This change to the proposed Desalination Amendment requires a diffuser unless the discharge is buoyant as a result of comingling with wastewater. If wastewater becomes unavailable for dilution or there are other changes in the method of discharge, the regional water board would issue a new or amended permit based on the revised operating conditions. The regional water boards have the option to conditionally permit desalination facilities than plan on comingling with the permit condition that if wastewater becomes unavailable, a new Water Code section 13142.5(b) determination would be required. The reissuance of an NPDES permit may take some time; however, if comingling stops or there is inadequate volume to meet the receiving water limitation, an owner or operator must either comply with the receiving water limitation or cease operations. If not in compliance with the receiving water limitation for salinity, further operation would be a violation, and the regional water board could take an enforcement action on the facility.

COMMENT BRH24

Comments on Conclusion 5

I do not have the expertise to provide any comments on the effectiveness of ETM/APF models

Appendix I Responses to the External Peer Review of the Proposed Desalination Amendment

RESPONSE TO BRH24

Comment noted.

2. Lisa A. Levin, Ph.D. (LAL)

COMMENT LAL1

Comments are provided here on conclusions supporting the proposed Desalination Amendments and on the *Substitute Environmental Document* that contains the draft staff report. I reviewed the documents with the understanding that the Amendments provide procedures for Regional Water Boards to evaluate 1) the best site, design, technology, and mitigation measures to minimize adverse impacts to aquatic life at new or expanded desalination facilities; 2) industry specific receiving water limits for salinity; 3) implementation and monitoring provisions for discharges of waste brine; and 4) provisions protecting sensitive habitats, species, Marine Protected Areas, and State Water Quality Protection Areas from degradation associated with desalination intakes and discharges; and 5) monitoring requirements.

As requested I provide a critique of the 5 conclusions and general assessments of the materials provided.

RESPONSE TO LAL1

Comment noted.

Conclusion 1: A receiving water salinity limit of two parts per thousand (ppt) above natural background salinity is protective of marine communities and beneficial.

COMMENT LAL2

This statement may be true in some places and in some years but will probably not be true at all sites and times. In stable settings with little salinity variation a 2 ppt elevation of salinity may not be tolerated, and while not necessarily lethal could induce sublethal effects. Continuous measurements at the recurrent location of squid egg beds at 25 m water depth off So. Cal. yielded a salinity range of 33.22-33.90 over a year (Navarro 2014). With such constant values it hard to believe that an increase of 2 (to 35.2) would have no effect on embryo or paralarval development. Establishing natural variability and local adaptation seem important. The nature of variability is just as important in establishing receiving water limits as the amount of variation, as indicated by this plot of salinity variation at the outfall off Huntington Beach. Natural variability involves significant episodic *drops* in salinity by 2 ppt, but never a rise of this magnitude. Representing variability as 9.7% in this case does not tell a realistic story, since natural exposures rarely rise above 34. Another measure of variability should be considered since the disturbance at hand involves elevated salinity – perhaps by calculation of variance above the mode or mean. Certainly 37 for a numeric limit seems unrealistic for California waters (except perhaps in our inverse, hypersaline estuaries).

RESPONSE TO LAL2

Please see response to comment BRH2 in the Dr. Ben R. Hodges Peer Review. Although testing the response to salinity for all marine species would be beneficial, it would take significant time and resources. For this reason, model species are often used. In the development of water quality criteria, U.S. EPA aquatic life guidance requires testing of one species from eight families (USEPA, 1985) and acknowledges that it is not practical

Appendix I Responses to the External Peer Review of the Proposed Desalination Amendment

to evaluate every species. See

<http://water.epa.gov/scitech/swguidance/standards/criteria/aqlife/upload/85guidelines.pdf>

If additional data become available that suggests the proposed receiving water limit for salinity is inadequate, the State Water Board can revise the value as needed. U.S. EPA established a salinity guideline for marine waters not to exceed marine water salinity by more than ten percent. See

http://water.epa.gov/scitech/swguidance/standards/criteria/aqlife/upload/2009_01_13_criteria_goldbook.pdf

The receiving water limitation for salinity in the proposed Desalination Amendment is approximately 5 percent above natural background salinity and is thus more conservative than the U.S. EPA standard.

COMMENT LAL3

Climate change must be considered as a growing stressor on the CA shelf. Drought in particular is likely to alter background salinities and salinity gradients and place additional stress on estuaries. Beyond absolute changes in salinity, alteration of gradients may negatively affect species that depend on estuarine salinity gradients for reproduction, migration or osmoregulation.

RESPONSE TO LAL3

The proposed Desalination Amendment addresses seawater desalination intakes and discharges into ocean waters. Impacts to water quality related to climate change, and desalination intakes and discharges of brine into estuaries and inland surface waters, are out of the scope of the proposed Desalination Amendment. Estuaries are dynamic environments and have many site-specific considerations. Consequently, the regional water boards regulate waste discharges, including brine discharges, into estuaries on a case-by-case basis. Brine discharges into estuaries and impacts to water quality related to climate change may be addressed in later amendments to the applicable water quality control plans.

COMMENT LAL4

Salinity Testing. Salinity tolerance testing is described for a suite of species to achieve standardization (WET testing). Among the initial targets was *Mytilus galloprovincialis*, invasive species originating from the Mediterranean (where salinity is 38ppt). Although this species is farmed in Carlsbad, it is a bay species sure to be more tolerant of high salinity than for example the California mussel, *M. californianus*, an open coast species that plays key roles in habitat formation. Few commercially important species were tested. The red urchin, *S. franciscanus*, anchovy, CA halibut, market squid, sardine and others would be appropriate. The argument that only lab reared /standard testing species should be used to establish salinity limits and regulations is unfounded. Most wild populations exhibit various forms of local adaptation. It is this region-specific adaptation in wild populations that should be the basis of the regulations. I recommend testing key (commercial for foundational) local species in each system.

RESPONSE TO LAL4

Comment noted. Phillips et al. (2012) relied upon standard protocols and methods in the existing California Ocean Plan (Table III-1) that were developed and implemented in

Appendix I Responses to the External Peer Review of the Proposed Desalination Amendment

accordance with California Water Code sections 13170.2(c) and (d). Please see responses to LAL2 and LAL3, and response to comment 6.10 in Appendix H of the Staff Report with SED.

COMMENT LAL5

Research Needs and Additional Considerations. In general available data for responses to hypersalinity (brine discharge) are very limited.

What are the tolerances of the organisms comprising the planktonic food web? The brine discharge will affect everything from microbes and phytoplankton to copepods and chaetognaths, but these are not considered. Why? Ecosystem-level consequences must be addressed.

Where is the discussion of sublethal effects on reproduction of key species?

RESPONSE TO LAL5

The proposed Desalination Amendment was developed using the best available science. The State Water Board convened an Expert Review Panel on Impacts and Effects of Brine Discharges (ERP I) (Roberts et al. 2012) and commissioned a salinity toxicity study (Phillips et al. 2012) to provide additional information regarding salinity toxicity. However, the State Water Board acknowledges the benefits of the research needs identified and will review and consider new data and information as it becomes available. The California Ocean Plan (Ocean Plan) is periodically reviewed to ensure that the requirements included are protective of beneficial uses. As new data and information are generated, the State Water Board can consider the need to update the requirements related to the discharge of brine waste. Please see response to LAL2 and LAL3.

COMMENT LAL6

• Why is there no mention of salinity effects in combination with other compounds associated with RO? Is salinity the *only* alteration relative to normal seawater?

RESPONSE TO LAL6

The scope of the proposed Desalination Amendment addresses salinity-related toxicity. There may be other alterations from desalination discharges relative to normal seawater. However, as described in section 8.8 of the Staff Report with SED, the regional water boards will continue to regulate antiscalants, biocides, and cleaning in place liquids. Furthermore, all other applicable portions of the Ocean Plan will apply to discharges from desalination facilities. All chemical-specific aquatic life water quality objectives are derived from exposures to the pollutant of interest. While it is important to consider the effects of multiple compounds, there may be synergistic or agonistic effects associated with mixtures. These interactions are difficult to assess and even more challenging to develop thresholds based on those effects. Whole effluent toxicity (WET) testing and the toxicity objectives are relied upon to address the effects of mixtures in the effluent. WET testing is also beneficial for identifying toxicity of pollutants for which a numeric objective does not exist. Receiving water monitoring of water quality and biota is used in conjunction with narrative and numeric objectives to ensure that beneficial uses of the receiving water are not degraded by pollutants in the discharge.

Appendix I Responses to the External Peer Review of the Proposed Desalination Amendment

COMMENT LAL7

Before setting final salinity limits, studies are also needed to address the interaction of seasonal hydrographic variation and climate change consequences (ocean acidification, hypoxia, warming) with brine effects. O₂ and pH vary seasonally and are declining on the shelf (Booth et al. 2014). At stressful levels do these affect tolerance to elevated salinity? What are the lethal and sublethal effects? Do these lead to altered prey capture? altered aggregation/schooling mechanisms?

RESPONSE TO LAL7

The State Water Board acknowledges the benefits of additional research. However the studies mentioned could take decades to provide meaningful results. The number of proposed desalination facilities is rapidly expanding in California and it is important to have regulation limiting salinity in the receiving waters. As more data emerge from studies, the State Water Board will review and consider all new data and information and can update the Ocean Plan accordingly. Please see response to LAL2 and LAL3.

COMMENT LAL8

I would re-emphasize the statements in Jenkins et al. on brine discharge that make clear the need for additional research – I would argue before setting limits. *Data on the effects of elevated salinity and concentrate discharges on California biota are extremely limited, often not peer-reviewed, not readily available, or have flaws in the study design. Studies are also needed on different types of concentrates and mixtures with antiscalants and other chemicals associated with RO.*

RESPONSE TO LAL8

Comment noted. Please see response to LAL7.

Conclusion 2: A subsurface seawater intake will minimize impingement and entrainment of marine life.

COMMENT LAL9

The use of subsurface intake systems is purported to improve water quality, reduce chemical use and environmental impact, reduce C footprint and cost of treated water (Missimer et al. 2013). As stated, Conclusion 2 is incomplete, as it claims minimization of impingement and entrainment of marine life – but relative to what? Presumably this is relative to a surface seawater intake? The conclusion may not be true relative to water from other sources (e.g. reuse from a power plant where 100% mortality has occurred, stormwater, rainwater) or to a no-action alternative. Subsurface seawater intake construction and operation will have ecological impacts but there appear to be no studies of these. How will water overlying the intake bottom be affected and will intake drawdown rates be slower than swim speeds of larvae? Often the assumption is made that shallow, nearshore, sand-covered seabed is more or less expendable, but it does serve important ecological functions. For example subtidal sands provided habitat for infaunal invertebrates fed on by demersal fishes, or as nursery grounds (e.g. for CA halibut – Fodrie and Levin, 2007). Water sucked downward through sediments will involve some loss of invertebrates and fishes – as larvae and adults – and thus loss of ecosystem services. Although they will be localized, these should be quantified and compared to losses from other sources.

Appendix I Responses to the External Peer Review of the Proposed Desalination Amendment

As intake technology advances there needs to be options for new approaches. The amendment should include adaptive language to accommodate (and require use of) new, improved technologies as they develop. Subsurface intake options need to be evaluated in light of cumulative impacts and habitat status. For example sand mining for beach replenishment is a growing practice off southern California. Cumulative impacts on the seabed of mineral removal, seawater intake, trawling and other sources of disturbance (hypoxia or other water quality issues) should be evaluated together.

RESPONSE TO LAL9

Conclusion 2 should state that subsurface seawater intake will minimize impingement and entrainment of marine life relative to a screened surface intake. There may be construction-related impacts to marine life associated with constructing subsurface infiltration galleries, however the construction-related impacts to marine life associated with all other types of subsurface intakes (e.g. beach wells, Rainey wells) will be insignificant or non-existent. Even though the construction of subsurface infiltration galleries will disrupt benthic communities, the benthic communities will recolonize the area (SCWD 2009), and the disruption will be short-lived relative to a surface water intake where impacts will continue for the operational lifetime of the facility.

Subsurface intakes are the preferred intake technology because there is no operational mortality associated with the intake of seawater. As stated in section 8.3.2 of the Staff Report with SED, subsurface intakes provide a natural barrier to suspended sediments, algal toxins, pathogens, dissolved or suspended organic compounds, harmful algal blooms, kelp, sea jellies, debris, or oil or chemical spills, and adult and juvenile marine organisms. (Missimer et al. 2013; MWDOC 2010; Lattemann and Hopner 2008; Kreshman 1985) Subsurface intakes collect water through sand sediment, which acts as a natural barrier to organisms and thus eliminates impingement and entrainment. (MWDOC 2010; Missimer et al. 2013; Hogan 2008; Pankratz 2004; Water Research Foundation 2011)

There are no studies to support the claim that water withdrawn downward through sediments will involve some loss of invertebrates and fishes and result in the loss of ecosystem services. In fact, the potential for impingement associated with the zone of influence for subsurface intakes is significantly less than that associated with surface water intakes. The velocities and potential for bottom impingement are very low due to the greater surface area and the porous media that water is moving through, especially when compared to lateral currents likely encountered at the sediment water interface. Below is an excerpt from MWDOC 2010 discussing this issue as it pertains to slant wells at the Doheny Beach project,

“The vertical infiltration rate of ocean water migrating downward through the seafloor during slant wellfield operation is estimated to be quite low, at approximately 0.000051 feet per second (ft/sec) in the immediate vicinity overlying the wellfield and 0.0000078 ft/sec at the outer limits of the ocean water source area (Williams 2010). This intake velocity is four orders of magnitude less than the 0.5 ft/sec through-screen velocity that has been found to be gentle enough to avoid impingement on the screens of

Appendix I Responses to the External Peer Review of the Proposed Desalination Amendment

conventional ocean intakes (SWRCB 2010). This slow rate of infiltration would be imperceptible to benthic organisms, which routinely experience much greater currents and wave surge in the active wave climate offshore Doheny Beach. This area is subject to significant sand transport and movement from San Juan Creek discharges, wave and tidal forces, and littoral currents. For example, during a March, 1983, storm, there were 20 foot high breakers off Dana Point and 7 to 13 foot high wave runup on Doheny Beach (Jenkins 2010). Such major storms cause as much as 7 foot loss in the thickness of beach sediment cover. Although the March, 1983, storm event is extreme, waves of 4 to 6 feet are common off Doheny Beach and the associated bottom surge from these waves at the shallow water depths of the wellfield produce forces on the sediment and the sediment-dwelling organisms that are much, much greater than the very slight drawdown from the wells.”

The proposed Desalination Amendment includes adaptive language to accommodate for new, improved intake and discharge technologies. Chapter III.L.2.d.(1)(c)(iii) allows for an owner or operator to use an alternative screening technology as long as the alternative technology provides equal protection as a 1.0 mm screen. The proposed Desalination Amendment was drafted with existing and proposed technologies in mind; however, as technological advances are made, if the existing amendment language does not provide adequate flexibility for the new technology, the language can be amended to require or support the use of the new technology.

Cumulative impacts will be evaluated on a project-specific basis taking into consideration site-specific considerations during the CEQA process for each desalination facility.

Conclusion 3: A 0.5 mm, 0.75 mm, 1.0 mm, or other slot size screens installed on surface water intake pipes reduces entrainment.

COMMENT LAL10

This statement is vague... as it does not specify screen size – only suggests that some sort of screen should be used. It is true that the screen will reduce entrainment relative to no screen, especially for fish. The screens are most effective for larger organisms but the mitigation requirements are based on organisms that presumably will go through the mesh. Many invertebrate larvae (bivalves and gastropods, some echinoderms, polychaetes are < 500 microns (0.5 mm in size), even when they are ready to settle. It seems the focus of the amendment is on fish larvae (and head size), but of course the food those fish eat (shellfish and polychaete larvae) will be entrained.

Generally organisms impinged on the screen will die. Accurate data are needed on how many and who is impinged and how the screens will avoid clogging. Next-generation /quantitative sequencing could be used to evaluate the composition of impinged residue and entrained individuals to accurately evaluate mortality ratios.

RESPONSE TO LAL10

It is important that the most protective surface intake is one that is designed for low velocity and is screened. The proposed Desalination Amendment requires a low velocity

Appendix I Responses to the External Peer Review of the Proposed Desalination Amendment

intake as well as a standardized maximum screen size to minimize or eliminate impingement and entrainment. Screen size selection represents a balance between operational and maintenance considerations and the protection of marine life. The draft Desalination Amendment was released on July 3, 2014, with a range of screen slot sizes to receive public comments on the screen slot sizes, but has been amended to support a 1.0 mm slot size. Please see response to comment 15.5 in Appendix H of the Staff Report with SED.

Conclusion 4: Multiport diffusers and commingling brine with other effluents can dilute brine discharge and provide protection to aquatic life.

COMMENT LAL11

This conclusion is probably true as stated... assuming that the concept of protection to marine life is in comparison with brine discharge in the absence of multiport diffusers and in the absence of dilution with other effluent. However, there is less protection than if there were no discharge at all.

RESPONSE TO LAL11

This comment is correct that the comparison is to a single port or outfall pipe without a diffuser. While some public comments have identified zero discharge as an option, the technology to achieve zero discharge, and ability to dispose or recycle the solids remains a significant hurdle.

COMMENT LAL12

There seems to be a lively debate afoot about whether multiport diffusers are a preferred alternative to in-plant dilution. Since not all organisms are killed that come in contact with turbidity from multiport diffusers, but 100% mortality is assumed for water used with in-plant dilution – then multiport diffusers would seem to be the preferred alternative. However, if the water used for dilution already had organisms killed (via power plant use) than this seems like a preferred option.

A major problem seems to be that turbulence studies have not been done with larvae many of the commercially harvested species in California (abalone, rockfish larvae, CA, Dungeness crabs, mussels, red urchin, squid etc.). Larvae may be rendered more vulnerable to turbulence-induced mortality through the effects of ocean acidification, warming or deoxygenation. Much more research is needed to evaluate multidiffuser effects on mortality of plankton and larvae via turbulence. The same is true for effects of low turbulence pumps for flow augmentation on mortality.

RESPONSE TO LAL12

Agree. There are no empirical studies that assess turbulence-related stress on marine life. The highly turbulent conditions at the point of discharge from multiport diffusers that could potentially be lethal to marine life would occur immediately adjacent to the outfall port and quickly dissipate. The duration of impact is also thought to be from ten to 50 seconds. The shear stresses in relation to distance from port for a jet are described in the report titled, “The Effects of Turbulence and Turbidity Due to Brine Diffusers on Larval Mortality: A Review by Philip Roberts and Kristina Mead Vetter” (See

Appendix I Responses to the External Peer Review of the Proposed Desalination Amendment

http://www.waterboards.ca.gov/water_issues/programs/ocean/desalination/docs/erp_final.pdf)

COMMENT LAL13

The amendment text should include adaptive language to accommodate (and require use of) new technologies that might be developed for brine discharge.

RESPONSE TO LAL13

Chapter III.L.2.d.(2)(c) of the proposed Desalination Amendment allows other technologies and approaches that provide equivalent protection to wastewater dilution if available, or multiport diffusers if wastewater is unavailable. As such, the proposed Desalination Amendment does not provide a complete list of all technologies that may be used; only that they meet similar performance requirements.

COMMENT LAL14

The discussion of discharge water options is very narrow and does not include the feasibility of (a) terrestrial disposal of brines (possible production of salt or other compounds) or (b) using stormwater or treated greywater for dilution. However, to consider dilution with municipal wastewater there needs to be research on the environmental consequences of brine + municipal wastewater.

RESPONSE TO LAL14

Terrestrial disposal or reuse of brines has not been proposed recently, but there are obvious benefits primarily associated with the fact that no discharge would occur. However, the additional costs and issues associated with salt deposition on land may outweigh such a benefit. Some large municipal wastewater facilities in southern California are currently diluting brine with wastewater, and the commingled discharge is achieved through diffusers. Reports from regional monitoring studies conducted by the Southern California Coastal Water Research Project indicate there are few environmental impacts that occur in the near coastal marine environment within the southern California Bight. However the regional monitoring studies are not designed to assess impacts associated with specific ocean discharges. Rather, these studies are intended to assess overall condition of the southern California Bight (http://ftp.sccwrp.org/pub/download/DOCUMENTS/Bight08_CE_Synthesis_web.pdf). For some commingled discharges, the salinity of the brine will balance the freshwater nature of the wastewater effluent and the discharge may be near-ambient salinity. As more facilities commingle brine with municipal waste, more data will become available regarding the environmental impacts of commingled discharges.

COMMENT LAL15

I found frequent use of the term 'any accessible approach' for evaluating mortality (e.g., due to shear stress, construction etc.) to be disconcerting. The language must be stronger making one of several approaches mandatory so that assessments cannot state that there is no feasible approach.

RESPONSE TO LAL15

The term "any accessible approach" used in chapter III.L.2.e.(1)(b) and (c) of the

Appendix I Responses to the External Peer Review of the Proposed Desalination Amendment

proposed Desalination Amendment is acceptable, in meaning that the approach meets general standards for study design, completeness, appropriate use of statistical analysis, and the data are representative of the system and of high quality. The language provided flexibility for research in these areas, but was revised to include regional water board approval of the methods.

COMMENT LAL16

There is a discussion of brine dilution with wastewater. The claim would be to use water not otherwise repurposed. But wastewater reuse is in its infancy in CA. Much water not currently recycled in California could be. It is likely that any water used for brine dilution will deflect consideration of recycling that water for other uses.

RESPONSE TO LAL16

There was a desire to ensure flexibility in terms of how brine dilution could be achieved. Commingling brine with wastewater is the preferred alternative because it results in the least amount of intake and mortality of marine life. The proposed Desalination Amendment was clarified that if wastewater is serving no other purpose, then it could be used to dilute the brine. There is no language in the proposed Desalination Amendment that prevents wastewater recycling efforts. Further, the regional water boards have the option to conditionally permit a facility proposing to commingle brine; and include a provision requiring an amendment if at some point the wastewater is recycled or becomes unavailable for dilution.

Conclusion 5: The Area Production Forgone (APF) method using Empirical Transport Model (ETM) can effectively calculate the mitigation area for a facility's intakes.

COMMENT LAL17

I disagree with this conclusion. This is the method used for calculating mitigation in the case of power plant entrainment and mortality. But it does not necessarily provide the optimal information required to understand what exactly is lost and what should be mitigated. Here are some of the issues I see.

a) The APF/ETM approach is one-dimensional and does not incorporate the ecosystem functions and services that are lost. Entrainment (and impingement) will kill everything from microbes, spores and phytoplankton to holo-zooplankton and meroplankton, in addition to fish larvae. Each of these functions as a component of the food web that supports higher trophic levels. In some cases the propagules develop into adult stages that serve as foundation species that provide habitat, refugia, nursery grounds and more (examples include mussel larvae that become mussel beds and kelp spores that become kelp beds). The focus on adults lost exacerbates this problem. E.g. p. 67 – the ultimate loss of 4 adult sheephead does not include the loss of 200,000 larval sheephead that may have been prey for squid or other commercial catch. None of these services are incorporated into the mitigation calculation. Marin facility loss of 229M herring, 1.8 M gobies, 0.615 M No. anchovy may not affect population sustainability but will surely affect the food web.

RESPONSE TO LAL17

Appendix I Responses to the External Peer Review of the Proposed Desalination Amendment

The ETM/APF model does not focus on adult loss, and one of the assumptions of the model is that the species assessed are representative of the species not assessed (see section 8.5 and Appendix E of the Staff Report with SED). The conclusion is stated based on a comparison of ETM/APF to other available mitigation assessment models. Other mitigation models (e.g. FH and AEL) consider the entrainment losses in context of the high natural mortality rates and the significance of the losses in terms of the effect to the population. One of the benefits of using the ETM/APF approach is that the output of the analysis is the number of acres of habitat needed to produce the same amount of productivity as was lost through the surface water intake. While the ETM/APF model does not provide a direct assessment of changes in a food web, or losses of ecosystem functions, the model estimates acres of habitat needed to offset losses. The concept is that once the habitat is successfully mitigated, it will benefit all species in the ecosystem, including the species that were not assessed in the ETM/APF analysis (e.g. microbes, spores and phytoplankton to holo-zooplankton and meroplankton, in addition to fish larvae). The available mitigation assessment models are described in Section 8.5 of the Staff Report with SED along with why the ETM/APF approach is the most appropriate for assessing impacts associated with surface water intakes at desalination facilities.

COMMENT LAL18

b) There is large variability in the model estimates. The models are very sensitive to selection of mortality rates. Much of the life-history information needed for modeling (e.g. life tables and population growth rates under different environmental regimes) is not available.

RESPONSE TO LAL18

Disagree, as described in Steinbeck et al., 2007, and included in Appendix E of the Staff Report with SED, the only life history information required for the Empirical Transport Model is an estimate of the duration of the period of time the larvae are vulnerable to entrainment. This estimate is based on the age of those larvae entrained. Other potential methods considered require much more life history information that includes significant uncertainty (Steinbeck et al., 2007). Furthermore, the proposed Desalination Amendment requires an owner or operator to use the 95 percent upper bound confidence level associated with the APF calculation to address some of the statistical uncertainty associated with the analysis.

COMMENT LAL19

c) There is no density dependence in the models. With fewer larvae growth rates should be faster.

RESPONSE TO LAL19

That statement is correct; however the effects would be negligible. Please see Appendix E in the Staff Report with SED.

COMMENT LAL20

d) There is no independent means to test the validity of the models used.

RESPONSE TO LAL20

Although there is no directly measurable parameter to test the validity of the models,

Appendix I Responses to the External Peer Review of the Proposed Desalination Amendment

Appendix E of the staff report with SED includes guidance for the appropriate design of studies and application of the model to reduce uncertainty associated with the models. The report titled **Extrapolating Impingement and Entrainment Losses to Equivalent Adults and Production Foregone** published by the Electric Power Research Institute (EPRI) (2004) described approaches that could be used to assess the species-specific parameters including changes in fish population changes over time as well as other factors may be used to assess the validity of ETM parameters.

COMMENT LAL21

e) Many species are migratory and originate from or settle outside the project area. The APF does not recognize this. Recognition of source-sink properties of sites (in terms of larval connectivity) must be part of the loss calculations and mitigation determinations. Regulations address distance from an MPA or SWQPA but much research has shown that oceanographic connectivity and realized biological connectivity (determined from genetic or trace elemental fingerprinting tools) are not necessarily directly related to distance (White et al. 2010; Watson et al. 2011). In southern California connectivity can be highly seasonal (Carson et al. 2010) and exhibit interannual variation (Cook et al. 2014).

RESPONSE TO LAL21

Disagree. Representative sampling of both the source water and intake water is required in order to calculate the Area Production Foregone. Please see Section 8.5 and Appendix E of the Staff Report with SED.

COMMENT LAL22

f) There is a need for more information on mortality of eggs and larvae and juveniles in low turbulence pumps for flow augmentation.

RESPONSE TO LAL22

Agree, chapter III.L.2.d.(2)(d)iii and iv of the proposed Desalination Amendment requires empirical studies to demonstrate the marine life mortality associated with flow augmentation, including mortality associated with low-turbulence pumps. An owner or operator cannot simply claim that a technology will be highly effective without demonstrating this to the regional water board. Comment letter 15 submitted to the State Water Board by Poseidon Resources in Appendix H of the Staff Report with SED, included two studies from the department of Fish and Game regarding the use of low-turbulence pumps at fish hatcheries. However, these studies looked at fish that were large enough to be excluded by a 1.0mm slot size screen. Studies on low-turbulence pumps should consider eggs, larvae, and juvenile fish smaller than 30 mm and should look at immediate and delayed mortality.

COMMENT LAL23

g) There is no discussion of mortality caused by monitoring or mitigation projects. There clearly will be some and these should be incorporated into mitigation calculations.

RESPONSE TO LAL23

Chapter III.L.2.e of the proposed Desalination Amendment requires that an owner or operator fully mitigate for mortality of all forms of marine life associated with the

Appendix I Responses to the External Peer Review of the Proposed Desalination Amendment

facility. There is also a provision that requires mitigation for the entrained marine life from the mitigation project. In addition, chapter III.L.2.a.(1) of the proposed Desalination Amendment states that “The regional water board in consultation with State Water Board staff may require studies or information if needed, including any information necessary to identify and assess other potential sources of mortality to all forms of marine life.” This statement allows the regional water board to require an owner or operator to assess and mitigate for any mortality associated with monitoring and mitigation.

COMMENT LAL24

h) Cumulative impacts from like projects (desalinization/power plants) and unlike projects (sand mining, trawling, shipping, spills etc.) must be considered in estimating mitigation requirements. For example, multiple desalinization plants proposed for southern California will impact adults and larvae of species that occupy the entire range. While mortality estimates for each plant individually may be mitigated, the loss of 4x the number from 4 plants may have a disproportionate influence on the dynamics of the population, and on subsequent trophic levels, competitors etc.

Response to LAL24

Please see response to comment LAL47 below.

COMMENT LAL25

i) Greenhouse gas emissions and other project-associated actions that degrade the environment should be calculated in the mitigation requirement. These are not estimated for Carlsbad or Huntington Beach... which claims carbon neutrality but this is unlikely and proof is required before installation.

RESPONSE TO LAL25

The Carlsbad and Huntington Beach facilities were presented as examples of impacts associated with desalination facilities in general. In both examples, the facility owners or operators are required to develop plans that explicitly state how each facility will achieve carbon neutrality and describe how neutrality will be demonstrated.

COMMENT LAL26

j) New methodologies that can improve the estimation of lost individuals, species, functions and services should be adopted whenever possible. This might include visualization tools at the intake (optical particle counters), and next generation molecular tools that can accurately identify losses, biodiversity effects, numbers of species etc.

RESPONSE TO LAL26

Agree. As technologies improve, and services to provide those new technologies grow, it will be important to consider those relevant and more sophisticated methods in the future. As technological advances are made, the new approaches can be implemented through future amendments to water quality control plans, policies, or through requirements in NPDES permits for individual desalination facilities.

COMMENT LAL27

k) **Remediation** – very little is said about avoidance of impact through timing of intake or

Appendix I Responses to the External Peer Review of the Proposed Desalination Amendment

reducing flow. There is a need to think outside the box and develop innovative ways to deal with events – HAB, OA or hypoxia that heighten larval sensitivity or increase loss.

RESPONSE TO LAL27

Avoidance of impact through timing of intake or reducing flow is important to consider. However, due to the variable nature of conditions throughout coastal waters, these issues are more appropriately addressed through a facility's NPDES permit rather than on a statewide level. At this time there is little information on HAB related triggers, frequency and distribution of HABs, and ocean acidification to develop specific language. Impacts associated with hypoxia can be evaluated through monitoring of receiving water quality and biological resources.

Other comments on the desalinization amendment and supporting materials.

General Comments:

COMMENT LAL28

(1) The amendments need to include adaptive language to accommodate (and require) use of new technologies that provide advantages over old ones. These could include advances in intake methods, avoidance, monitoring techniques (molecular), use of solar power, reducing in reject water volume. The one place this appeared was p. 93 option 5. This should be a part of nearly all other amendments.

RESPONSE TO LAL28

The proposed Desalination Amendment supports the use of new and improved technologies for both intakes and brine discharges by allowing for alternatives that meet the performance criteria included in chapters III.L.2.d.(1)(c) iii and III.L.2.d.(2)(c) of the proposed Desalination Amendment.

COMMENT LAL29

(2) Desalinization plants are focused on developing potable water. There should be consideration of whether it is environmentally better to produce lower quality water (for non-potable use) that can replace (conserve) potable water that is now used for irrigation, toilets etc.

RESPONSE TO LAL29

This is an important issue to consider, but will be addressed by the water providers as to the best use of their resources to deliver a clean and reliable water source to their customers. Neither the existing Ocean Plan nor the proposed Desalination Amendment is intended to address the uses of potable versus non-potable water. The purpose of the proposed Desalination Amendment is to provide guidance and direction on how to protect beneficial uses of ocean water if a desalination facility is proposed.

COMMENT LAL30

(3) I found many items missing or treated inadequately in the discussions provided. Whether these are discussed elsewhere – I am not sure.

- Energy and carbon footprints of construction, operation, monitoring and mitigation should be quantified and incorporated into decision-making as well as mitigation requirements.

RESPONSE TO LAL30

Appendix I Responses to the External Peer Review of the Proposed Desalination Amendment

These analyses are not required under the Ocean Plan or included in the proposed Desalination Amendment because both require programmatic-level CEQA. Each individual desalination project will be required to assess air quality greenhouse gas emissions and associated mitigation through the CEQA process for the project.

COMMENT LAL31

- Socioeconomic impacts of increased cost of water (via desalinization) should be considered.

RESPONSE TO LAL31

This is an important issue to consider, but will be addressed by the water providers as to the best use of their resources to deliver a clean and reliable water source to their customers. Neither the existing California Ocean Plan nor the proposed Desalination Amendment is intended to address the uses of potable versus non-potable water. The purpose of the proposed Desalination Amendment is to provide guidance and direction on how to protect beneficial uses of ocean water if a desalination facility is proposed.

COMMENT LAL32

- Climate change factors (warming, ocean acidification, ocean deoxygenation, sea level rise) should influence site selection, intake method and location, discharge sites, and timing of intake.

RESPONSE TO LAL32

These issues are important global issues, but are out of the scope of the proposed Desalination Amendment. Some of these issues will be addressed for projects during the approval process for the Coastal Development Permit (e.g. sea level rise). The State Water Board may consider addressing climate change-related issues in future water quality control plans or policies.

COMMENT LAL33

- There should be consideration of opportunities to use existing degraded areas for discharge (harbors or other).

RESPONSE TO LAL33

Disagree. Harbors, though highly modified from natural or preindustrial conditions that once existed, still serve as important nursery or spawning habitats for many marine species. The resident fish support a considerable recreational fishery for many shore and boat based fishers. Providing opportunities to use existing degraded areas would pose the risk of making already degraded habitats worse.

COMMENT LAL34

- There is virtually no consideration of habitat loss and ecosystem services that derive from the environmental impacts. For example, while loss of eel grass bed services such as nursery habitat is considered, the value of eel grass for carbon sequestration, remediation of ocean acidification, storm buffering etc. is not. Secondary effects of larval loss as prey, and changes to food webs must also be considered. All of this should be incorporated in cost-benefit analyses and mitigation compensation.

RESPONSE TO LAL34

Disagree. By restoring, creating, or enhancing habitat, those ecosystem functions and

Appendix I Responses to the External Peer Review of the Proposed Desalination Amendment

services would be mitigated as well.

COMMENT LAL35

• There was no discussion of the potential for harmful algal blooms and release of toxins (such as occurred in Lake Erie and affected drinking water). Is that an issue for So. California?

RESPONSE TO LAL35

The proposed Desalination Amendment addresses seawater desalination intakes and brine discharges into ocean waters. There is no information to support that HAB-related issues are correlated with desalination facilities. The issue of HABs and the release of toxins is an important statewide issue. However, more research is needed before a statewide plan or policy can be developed to address HABs. Issues associated with drinking water quality and permits are addressed by the State Water Board's Division of Drinking Water. Drinking water quality is outside the scope of the proposed Desalination Amendment. If there are HAB-related issues that impair the water quality of desalinated water, they will be addressed through a facility's drinking water permit.

Comments on existing text.

COMMENT LAL36

Definitions of sensitive habitats do not include coastal salt marshes or mudflats, or estuarine habitat. While these are not being considered as site, intake or discharge locations (with direct impacts), coastal mudflats and marshes are transition zones with exchange of energy, sediments, larvae and are migratory pathways.

RESPONSE TO LAL36

The habitats described do not commonly occur in ocean waters as described in the Ocean Plan and are thus outside of the scope of the proposed Desalination Amendment.

COMMENT LAL37

Definitions. Update the description of estuaries and lagoons... Southern California lagoons are largely inverse estuaries and are subject to closing. This produces very different dynamics and vulnerabilities.

RESPONSE TO LAL37

Changing the definition of the term "estuaries" will not affect the implementation of the proposed Desalination Amendment as it is primarily focused on ocean waters.

COMMENT LAL38

Why is there no discussion of geohazards and connectivity for siting?

RESPONSE TO LAL38

Geohazards and connectivity will be addressed through a facility-specific CEQA process, or during the regional water board's determination of best available site feasible.

COMMENT LAL39

Why are all regulations about salinity? What about other constituents of brine (e.g. in Australia Ba, Ca, K.Sr, Mg – Dupavillon and Gillanders 2009)

Appendix I Responses to the External Peer Review of the Proposed Desalination Amendment

RESPONSE TO LAL39

Osmotic stress was the primary factor addressed in the proposed Desalination Amendment because most other constituents in waste discharges are already addressed in the Ocean Plan. The individual components of salinity, including Na, Cl, Ba, Ca, K, Sr, Mg, and others could be added to Table 1 of the Ocean Plan if data and information become available to indicate that concentrations of these constituents above a certain threshold are causing harm to aquatic life.

Mitigation.

COMMENT LAL40

a. Very little is specified about mitigation. I may have missed these but where do specifications appear?

RESPONSE TO LAL40

Mitigation is addressed in chapter III.L.2.e of the proposed Desalination Amendment and discussed in detail in section 8.5 of the Staff Report with SED. The proposed Desalination Amendment includes requirements for mitigation assessment, options a project proponent can select for mitigation, and includes performance criteria to ensure that the selected mitigation project is actually replacing the lost productivity.

COMMENT LAL41

b. *One key recommendation I have is to consider funding research as mitigation.* Review of the documents reveals considerable need for experimental data regarding salinity tolerances, diffuser impacts and more. The desalinization industry should contribute to an independently administered research fund that addresses the many impacts of desalinization construction, intake, discharge and other operations.

RESPONSE TO LAL41

Research plays an important role in ensuring water quality plans are protective of beneficial uses. However, putting mitigation funding towards research would not replace lost productivity and would not fully mitigate for impacts.

COMMENT LAL42

c. Mitigation ratios of 1:1 are mentioned but these seem unusually low. Current approaches look only at loss of larvae as affecting adult populations, but not at the reverberations in the ecosystem or food web. When larvae are lost there are predators that go without food, effects on their predators, etc.

RESPONSE TO LAL42

The proposed Desalination Amendment was revised to give the regional water boards flexibility to increase the mitigation ratio to account for uncertainty associated with the mitigation project. See chapters III.L.2.e.(3)(b)vi and vii of the proposed Desalination Amendment. For more soft-bottom and open coastal habitats that are impractical to mitigate, the mitigation ratio maybe lower as long as overall productivity is equivalent to or higher than what was lost.

Appendix I Responses to the External Peer Review of the Proposed Desalination Amendment

The ETM/APF model does not simply consider the adult fish lost but calculates the habitat area necessary to replace the organisms in a marine ecosystem that were lost at a screened surface intake. Please see section 8.5 and Appendix E of the Staff Report with SED.

COMMENT LAL43

d. In the current plan area affects (> 2 ppt) are independent of food chain impacts.

RESPONSE TO LAL43

Disagree, as all mortality from construction, as well as intake and discharge for the operational lifetime of a facility, must be included in the mitigation calculation.

COMMENT LAL44

e. Mitigation could expand MPAs or help enforce MPAs.

RESPONSE TO LAL44

Provisions in chapter III.L.2.e.(3)(b)i of the proposed Desalination Amendment, allow mitigation projects that would create or expand MPAs as that additional MPAs could directly increase in productivity. Funding of enforcement of MPAs is not considered as an option because the Department of Fish and Wildlife enforces the MPAs, making it difficult or impossible to determine the enforcement efforts that would result in the amount of productivity needed to offset the losses from the desalination facility.

COMMENT LAL45

f. A fee based mitigation bank does not exist in CA for marine life. Do we really want to start this? It will remove direct responsibility from industry.

RESPONSE TO LAL45

Throughout stakeholder outreach for the proposed Desalination Amendment, numerous stakeholders have expressed interest in developing an in-lieu fee program for impacts associated with cooling water and desalination intakes that would be similar to a wetland mitigation bank. The proposed Desalination Amendment includes placeholder language for when such a program is developed, but also includes strict standards to ensure the mitigation program is successful. One benefit to establishing an in-lieu funding program is that the mitigation can be done by organizations with a history of completing successful mitigation projects and that have set and met performance standards in past projects. The industry will still be held to the requirement that impacts from a desalination facility be fully mitigated for the operational lifetime of the facility.

Research needs:

COMMENT LAL46

• There is little reporting on the vertical distributions of fish and invertebrate larvae. This should be determined to evaluate intake and discharge depths.

RESPONSE TO LAL46

Data on the vertical distributions can be evaluated and considered while determining the best available design feasible to minimize intake and mortality of all forms of marine life.

Appendix I Responses to the External Peer Review of the Proposed Desalination Amendment

Monitoring of the source water and intake will provide an understanding of the species present, and likely to be entrained; as well as how to site and design intakes and discharges to minimize impacts.

COMMENT LAL47

• Cumulative impacts are only mentioned on p. 64 of the staff report for same-source water body; it is unclear what this means.

RESPONSE TO LAL47

Cumulative impacts are mentioned several times in the document (see sections 5.3, 5.5, 8.4.8 of the Staff Report with SED). Further, section 12.1.18 of the Staff Report with SED addresses cumulative impacts associated with the project. The reference to cumulative impacts on page 64, section 8.4.8 of the Staff Report with SED states,

“Siting requirements would include an analysis of the cumulative impacts of the desalination facility in combination with other anthropogenic effects to marine life. Meaning, if there are multiple facilities being planned within the same area or region, and the facilities are using the same source water body, each facility’s section 13142.5(b) determination should also consider the fact that a shared ecosystem will be impacted.”

Cumulative impacts should be considered during the Water Code 13142.5(b) determination process as well as during a facility’s CEQA process. In areas such as Monterey Bay, there are several desalination projects being proposed. These facilities should be sited in consideration of each other as well as in consideration of all other siting factors to consider in order to minimize intake and mortality of all forms of marine life.

COMMENT LAL48

• More creative thought is needed to address desalinization impacts and mitigation. The state should consider convening workshops on mitigation requirements and how to assess whether criteria are met.

RESPONSE TO LAL48

The State Water Board convened two Expert Review Panels on Intake Impacts and Mitigation (ERP II & III) to assess the best mitigation for impacts associated with cooling water and desalination facility intakes (Foster et al. 2012 and 2013). The best available science provided by the expert review panels was used to develop the mitigation requirements in the proposed Desalination Amendment. We agree that if the proposed Desalination Amendment is adopted, future workshops on mitigating impacts from desalination facilities may be needed. It is the intent of the Water Boards to collaborate with other agencies having the authority to permit desalination projects and require mitigation (e.g. California Coastal Commission, California Department of Fish and Wildlife, State Lands Commission) to ensure the mitigation projects are the best available mitigation measures feasible (see chapter III.L.2.e.(3)(c) of the proposed Desalination Amendment).

Appendix I Responses to the External Peer Review of the Proposed Desalination Amendment

COMMENT LAL49

- Housing and Development assessment. A ready supply of desalinated water may reduce pressure for landscape-based approaches to water conservation and infiltration/reuse.

RESPONSE TO LAL49

This is an important issue to consider, but will be addressed by the water providers as to the best use of their resources to deliver a clean and reliable water source to their customers. Neither the existing Ocean Plan nor the proposed Desalination Amendment is intended to address the uses of potable versus non-potable water. Ideally desalination would be used in conjunction with existing programs that stress water efficiency and reuse. The purpose of the proposed Desalination Amendment is to provide guidance and direction on how to protect beneficial uses of ocean water if a desalination facility is proposed.

Unclear statements

COMMENT LAL50

- p. 64. Clarify 'same source water body' for cumulative impacts.

RESPONSE TO LAL50

Please see response to LAL47.

COMMENT LAL51

- Text missing in some places ... low key language?

RESPONSE TO LAL51

Not clear where the specific errors are that are being referred in this comment, however the text in the proposed Desalination Amendment and Staff Report with SED have been corrected when errors were found.

COMMENT LAL52

- Operator-determined construction impacts may not be wise.

RESPONSE TO LAL52

Construction-related impacts will be assessed in the Marine Life Mortality Report, which is then reviewed and approved by the regional water boards in consultation with State Water Board staff.

COMMENT LAL53

- . Text p. 142. How can the Carlsbad desalination proposal claim no operational impacts on biological resources? Is this because reused water already has 100% mortality? Does this apply to significant and non-significant impacts?

RESPONSE TO LAL53

The re-used water already has 100 percent mortality, so there is no additional mortality at the intake of the desalination facility that hasn't already occurred at the powerplant intake. This is described as an insignificant impact. (See http://carlsbaddesal.com/Websites/carlsbaddesal/images/eir/EIR_4_3.pdf)

Appendix I Responses to the External Peer Review of the Proposed Desalination Amendment

This is one of the benefits of desalination facilities co-locating with power plants. However, as power plants come into compliance with the OTC Policy, and the cooling water becomes unavailable, desalination facilities will have to acquire source water from another source.

COMMENT LAL54

• The energy intensive nature of desalinization is pointed out but should be incorporated into decision-making.

RESPONSE TO LAL54

The State Water Board's authority is limited to water quality issues. The California Ocean Plan does not include criteria related to energy use and neither does the proposed Desalination Amendment. Energy use and its impact on the environment will be evaluated by project proponents under CEQA.

References Cited:

Booth JAT, Woodson CB, Sutula M, Micheli F, Weisberg SB, Bograd SJ, Steele A, Schoen J, Crowder LB . Patterns and potential drivers of declining oxygen content along the southern California coast. *Limnol. Oceanogr.* 59:1127-1138 (2014)

Carson, H.S., Lopez-Duarte, M.P., Wang, D. and Levin, L.A. Time series reveals how reproductive timing alters coastal connectivity. *Current Biology* 20: 1926-1931. (2010)

Cook, G.S., P.E. Parnell. L.A. Levin. Population connectivity shifts at high frequency within an open-coast marine protected area network. *PLOS One*. (in press)

Fodrie, F. J. and L. A. Levin. Linking juvenile habitat utilization to population dynamics of a coastal finfish: nursery contribution, connectivity and concentration. *Limnology and Oceanography*, 53: 799-812. (2008)

Navarro, M. Consequences of environmental variability for spawning and embryo development of inshore market squid *Doryteuthis opalescens*. *UC San Diego. PhD Thesis (expected Sept. 2014)*.

Watson, j.R., Mitarai, S., D.A. Siegel, J.E. Caselle, C. Dong, J.C. McWilliams. Realized and potential larval connectivity in the southern California Bight. *Mar. Ecol. Progr. Ser.* 401: 31-48 (2010)

White, C., Selkoe, K. Watson, J., Siegel, D., Zacherl, D., Toonen. R. Ocean currents help explain population genetic structure. *Proc. R. Soc. B.* 277: 1685-94. (2010)

3. E. Eric Adams, Ph.D., P.E. (EEA)

Conclusion 1 A receiving water salinity limit of 2 ppt above natural background salinity is protective of marine communities and beneficial uses.

COMMENT EEA1

I am not a biologist, but the value of 2 ppt does seem consistent with available toxicological studies. Moreover, an excess salinity of 2 ppt salinity (dilution of roughly 20) is certainly achievable if there is minimal far field build-up. See Conclusion 4 below. *Thus I am generally supportive of the conclusion.*

Studies such as Phillips et al. (2012) typically report tests with fixed duration exposures (e.g., 48, 72 hours). Yet these durations may not match the exposures experienced in the field. Presumably some motile organisms would avoid the near field plume or crawl/swim through it, thus experiencing shorter term exposures. On the other hand, stationary biota, such as benthic infauna, could experience longer durations of elevated salinity, especially if an outfall is located in a poorly flushed area where the back-ground build up could extend over a considerable distance. Ideally at least some tests with time-varying exposure should be conducted. This is similar to other situations with time-varying pollutant exposures such as waste heat (temperature) from power plants, for which a substantial body of literature exists.

Phillips and 7 others (2012). "Hyper-Salinity Toxicity Thresholds for Nine California Ocean Plan Toxicity Test Protocols." U.C., Davis, Department of Environmental Toxicology. Report prepared for California State Water Resources Control Board, Agreement Number 11-133-250.

RESPONSE TO EEA1

Agree. As described in chapter III.L4.a of the proposed Desalination Amendment, receiving water monitoring of water quality and biota will be used in conjunction with narrative and numeric objectives to ensure that beneficial uses of the receiving water are not degraded by pollutants in the discharge.

Conclusion 2 A subsurface seawater intake will minimize impingement and entrainment of marine life.

COMMENT EEA2

Missimer et al. (2013) discusses various types of subsurface intakes (vertical wells, angle wells, horizontal wells, radial wells, and seabed and beach galleries). The zones of influence of all systems as they intersect the seabed are much larger than the corresponding dimension of a surface intake, implying much lower velocities, meaning impingement is avoided. Also, the typical pore size of seabed sediments is small enough to avoid entrainment of fish larvae. *So I support this conclusion.*

RESPONSE TO EEA2.

Comment noted.

COMMENT EEA3

Other potential advantages of subsurface intakes are cited, including improved raw water

Appendix I Responses to the External Peer Review of the Proposed Desalination Amendment

quality, reduced chemical usage, reduced energy costs (hence GHG emissions) and reduced overall cost to consumers (their higher capital costs are more than offset by lower operational costs). There are a number of operational SWRO plants using surface intakes, but not too many big ones. Clearly some sites are better than others, hydro-geologically speaking, but it also seems that designers are being cautious. Also, many of the examples come from the Middle East, where land is more available than in more congested California.

Missimer, T.M., Ghaffour, N. Dehwah, A.H.A. Rachman, R. Maliva, R.G. and Amy, G. (2013). "Subsurface intakes for seawater reverse osmosis facilities: Capacity limitation, water quality improvement, and economics" *Desalination* 322: 37-51.

RESPONSE TO EEA3

Comment noted.

Conclusion 3: A 0.5, 0.75 or 1.0 mm, or other slot sized screens installed on surface water intake pipes reduces entrainment.

COMMENT EEA4

I am not a biologist, but the available studies do seem to indicate that fine mesh screens do protect against larval entrainment. *So I generally support this conclusion.* But I would defer to others as to the optimal mesh size, if indeed there is a single optimum. The critical size depends on the larval size which is a function of the species, site, season and year. While changing screens on a seasonal or annual basis would seem burdensome, it could be appropriate to choose a unique size for a given station.

Most of the entrainment research has been done for electric power plants which experience similar problems of entrainment, but on a larger scale. One way to reduce entrainment at power plants is to minimize intake flow rates (e.g., through variable frequency pumps or by shutting down units for scheduled maintenance) during critical windows of time when small larvae are most abundant. Depending on the seasonal demands for freshwater, perhaps similar approaches could be used at desalination plants.

RESPONSE TO EEA4

Comment noted. Chapter III.L.2.d.(1)(c) of the proposed Desalination Amendment specifies a 1.0 mm screen coupled with a maximum flow velocity of 0.15 meters per second to reduce impingement and entrainment from screened surface water intakes. In addition, chapter III.L.2.c.(2) of the proposed Desalination Amendment includes a requirement to analyze potential designs for surface intakes to minimize intake and mortality of all forms of marine life. This would allow the regional water board to include provisions in an NPDES permit that would require an owner or operator to minimize intake flow rates during certain periods of high larval abundance in the water or when certain sensitive species (e.g. abalone) are spawning.

Conclusion 4: Multiport diffusers and commingling brine with other effluents can dilute brine discharge and provide protection of aquatic life.

COMMENT EEA5

Appendix I Responses to the External Peer Review of the Proposed Desalination Amendment

Use of multiport diffusers and co-mingling of reject brine with other effluents can get near field dilution to within acceptable levels (~20). As shown below, so can pre-dilution directly with seawater (flow augmentation), as well as increasing discharge momentum. All approaches have some pros and cons that should be weighed. For a single dense plume discharging from a flat bottom at an angle θ_o relative to horizontal, into quiescent receiving water, the terminal plume rise height h and the “near field” dilution S_n are given by

$$h = c_1(\theta_o)D_oF_o \quad (1a)$$

$$S_n = c_2(\theta_o)F_o \quad (2a)$$

where D_o is the effective orifice diameter (accounting for flow contraction if any), F_o is the discharge Froude number, $F_o = u_o/(\Delta_o D_o)^{0.5}$, u_o is the exit velocity ($4Q_o/\pi D_o^2$), Q_o is the discharge flow rate, Δ_o is the reduced gravity [$g(\rho_o - \rho_a)/\rho_a$], g is gravity, ρ_o and ρ_a are the densities of the discharged brine and the seawater, respectively, and c_1 and c_2 are empirical coefficients. For $\theta_o = 60^\circ$, Abbessi and Roberts (2014) give $c_1 = 2.25$ and $c_2 = 2.60$. The plume produces dilution through the entrainment of ambient water, so the dilution S_n in Eq. 2a implies an effective flow rate entering the near field of $Q = Q_o S_n$. If the reduced gravity of the discharge results solely from a single source, i.e., brine with an excess discharge concentration Δs_o , then $\Delta_o \sim \Delta s_o$. The near field concentrations above background (Δs and Δc), of salinity and of any other contaminant (e.g., product of corrosion, or anti-fouling agent) discharged with concentration Δc_o , are given by $\Delta c_o/\Delta c = \Delta s_o/\Delta s = Q/Q_o = S_n$. Eqns 1a,2b can also be written

$$h = c_1 Q_o^{1/4} u_o^{3/4} / [(\pi/4)^{1/4} \Delta_o^{1/2}] \quad (1b)$$

$$S_n = c_2 (\pi/4)^{1/4} u_o^{5/4} / [\Delta_o^{1/2} Q_o^{1/4}] \quad (2b)$$

The above equations are for a single jet discharging just the brine from a desalination plant. The accompanying sketch depicts an arrangement where the discharged flow can be pre-diluted with either: i) seawater, ii) treated wastewater effluent, and/or iii) heated condenser cooling water from a power station, making a combined flow of RQ_o . The discharge is evenly distributed through N ports of a multiport diffuser making the flow per port equal to RQ_o/N . The reduced gravity of the combined flow is $[\Delta_o + (R-1)\Delta_p]/R$ where Δ_p is the reduced gravity of the pre-dilution flow, which is proportional to the pre-dilution excess salinity, i.e. $[g(\rho_p - \rho_a)/\rho_a] \sim \Delta s_p$, defined as positive for a dense flow. For example, if the pre-dilution comes from pure seawater $\Delta_p = \Delta s_p = 0$ while if it comes from treated wastewater effluent or heated condenser cooling water Δ_p and $\Delta s_p < 0$. Using Eqns 1b, 2b, the maximum plume height and the dilution are

$$h = c_1(\theta_o)Q_o^{1/4} R^{3/4} u_o^{3/4} / \{(\pi/4)^{1/4} N^{1/4} [\Delta_o + (R-1)\Delta_p]^{1/2}\} \quad (3a)$$

$$S_n = c_2(\theta_o)(\pi/4)^{1/4} N^{1/4} R^{5/4} u_o^{5/4} / \{ Q_o^{1/4} [\Delta_o + (R-1)\Delta_p]^{1/2} \} \quad (3b)$$

Again, the total induced flow rate is $Q = S_n Q_o$. Thus mass balances for the near field excess salinity and concentration above ambient are given by $\Delta c = [\Delta c_o + (R-1)\Delta c_p]/S_n$, and $\Delta s = [\Delta s_o + (R-1)\Delta s_p]/S_n$. The “effective” dilutions for salinity and concentration, in turn, are

$$S_{ns}' = \Delta s_o / \Delta s = S_n \Delta s_o / [\Delta s_o + (R-1) \Delta s_p] \quad (4)$$

$$S_{nc}' = \Delta c_o / \Delta c = S_n \Delta c_o / [\Delta c_o + (R-1) \Delta c_p] \quad (5)$$

Eqs 3-5 are exercised in the accompanying table. Note that for a given problem Q_o and Δ_o are fixed, while θ_o , R , u_o , N and Δ_p are design variables. Case 1 starts with base case parameters that do not meet a target near field dilution of 20 either for excess salinity Δs or excess concentration Δc (last two columns of the table). The remaining cases show that dilution increases (and a target of 20 can be easily achieved) by using a multi-port diffuser (increasing N ; Case 2), increasing discharge momentum (increasing u_o ; Case 3), pre-diluting the brine with neutrally buoyant seawater (increasing R with $\Delta_p = 0$; Case 4), and pre-diluting (co-mingling) the brine with relatively buoyant treated wastewater or heated water (increasing R and making $\Delta_p < 0$; Case 5).

So all of these options can provide improved dilution. On the negative side, increasing u_o and R may require deeper water depth or shallower discharge angle to avoid plume surfacing, while increasing N allows discharge in shallower water. These are capital cost issues. And increasing either u_o or R requires more pumping energy, an operating cost issue. Environmentally, increasing R causes more water to be withdrawn at the intake with potential impacts due to impingement and entrainment, as well as impacts on the discharge side due to turbulent shear. Increasing u_o by itself could also increase turbulent shear. But if you can use another effluent (i.e., treated wastewater or condenser cooling water) for pre-dilution, then you have already suffered the impacts with sourcing and using that water, and if you are going to discharge the other effluent to the ocean anyway, you might as well let it improve your dilution. In the case of treated wastewater, however, an evaluation should be made as to whether commingling is a more valuable use than re-use (direct or indirect).

The improved dilution from co-mingling comes from both increasing R and decreasing the reduced gravity. In the case of brine, the “effective dilution” is increased further because the pre-dilution flow has negative excess salinity. This is reflected in the higher value of $S_{ns}' = \Delta s_o / \Delta s$ representing the reduction in salinity, relative to $S_{nc}' = \Delta c_o / \Delta c$ representing the reduction in concentration. Indeed, if $[\Delta_o + (R-1)\Delta_p] = 0$, the effluent would be neutrally buoyant and the effective brine dilution would be infinite (Eq 4), given sufficient water depth. And if $[\Delta_o + (R-1)\Delta_p] < 0$ the effluent would be positively buoyant. A separate dilution equation would need to be applied because the diluted effluent would float on the ocean surface, rather than fall to the seafloor. Because ambient velocities are generally higher on the surface than on the bottom, such a plume is more easily flushed in the far field, resulting in less brine build up. On the other hand, an aesthetic drawback is that the plume would be visible.

To summarize, I certainly support the conclusion that diffusers and co-mingling can provide good near field dilution. Flow augmentation can also be used, but is somewhat less effective, and simply adjusting the exit velocity may also work. Because there are multiple environmental impacts to be minimized (intake entrainment/impingement, near and far field concentrations of

Appendix I Responses to the External Peer Review of the Proposed Desalination Amendment

brine and other discharged pollutants, plus turbulent shear) and some of these vary with site (e.g., variation in water depth and flushing) I do not believe a single strategy for dilution can be recommended.

RESPONSE TO EEA5

Agree. During the stakeholder outreach process for developing the proposed Desalination Amendment, many stakeholders identified the need for site-specific flexibility and flexibility to accommodate for future technological innovations. This flexible approach was included in chapters III.L.2.d.(2) of the proposed Desalination Amendment where commingling brine with wastewater was established as the preferred brine disposal technology, but if unavailable, brine can be discharged through multiport diffusers. The intent was to encourage dilution in order to minimize impacts on marine life and beneficial uses associated with elevated salinity. Chapters III.L.2.d.(2)(c) of the proposed Desalination Amendment allows for future technological innovations.

COMMENT EEA6

Following are several related comments. Many different locations within the plume have been used to define dilution (e.g., minimum dilution at maximum height, impact point dilution, near field dilution). The near field dilution is the most appropriate because it pertains to concentrations after discharge-induced mixing terminates. It is also relatively easy to measure. Roberts et al. (2012) suggests that evaluating dilution under quiescent ambient conditions (as above) is conservative, which is generally the case, but may not be true for a multi-port diffuser. Depending on diffuser orientation and port size, plumes from adjacent nozzles may interact. For example, Adams (1982) shows degradation in the performance of a “Tee” diffuser (manifold oriented parallel to shore) and improvement in the performance of a “Staged” diffuser (manifold oriented offshore) as ambient current increases. These applications were for condenser cooling water, with discharge flow rate and momentum considerably higher than found in typical brine discharges, so the issue will not be as acute. Nonetheless there has been very little study of dense multi-port discharges in a current.

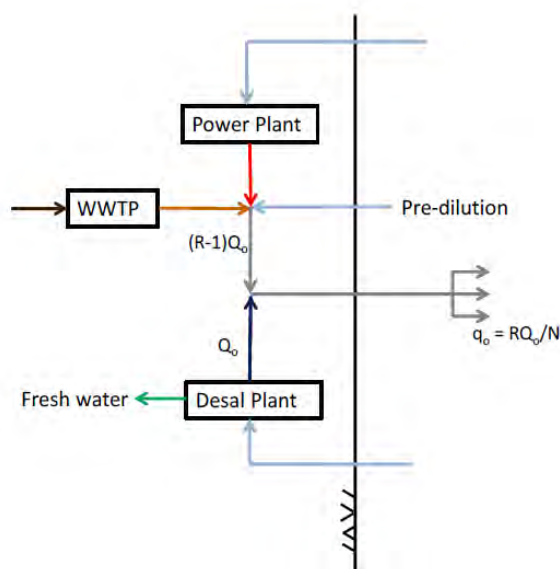

Appendix I Responses to the External Peer Review of the Proposed Desalination Amendment

All of the above relates to near field mixing. Roberts et al. (2012) correctly notes that one needs a combined near and far field analysis. It does little good to obtain tremendous near field mixing if the discharge area is poorly flushed, as the discharge will simply mix with itself allowing concentrations to build up. While the literature is replete with analyses of near field mixing (e.g., formulae such as Eqs. 1-2), there have been fewer published analyses of far field mixing, combined with near field mixing, applied to brine discharges. A good example or two would help regulators/designers.

Case	Q _o	Δ _o	N	u _o	R	Δ _p	h	S	D _o	F	Δs _o /Δ _s	Δc _o /Δc
	(m ³ /s)	(m/s ²)		(m/s)		(m/s ²)	(m)		(m)			
1-base case	0.1	0.3	1	1.5	1	0	3.3	13.1	0.29	5.1	13.2	13.2
2-diffuser	0.1	0.3	6	1.47	1	0	2.1	20.1	0.12	7.7	20.1	20.1
3-momentum	0.1	0.3	1	2.1	1	0	4.3	20.1	0.25	7.7	20.1	20.1
4 pre-dil (SW)	0.1	0.3	1	1.5	1.4	0	4.3	20.1	0.34	5.5	20.1	20.1
5- pre-dil (TWE)	0.1	0.3	1	1.5	1.25	-0.3	4.5	20.1	0.33	6.2	26.8	20.1

A simple way to combine the near and far fields is to first identify the far field, or background, concentration of water entrained in the near field (Adams, et al., 1981). The far field dilution can be defined as

$$S_f = (C_o - C_a) / (C_f - C_a) \quad (6)$$

while the near field dilution is

$$S_n = (C_o - C_f) / (C_n - C_f) \quad (7)$$

where C_a , C_f , C_n and C_o are concentration in the ambient receiving water, the far field, the near field and the discharge, respectively. Combining Eqs. (6 and 7)) yields an expression for the total dilution, $S_t = (C_o - C_a) / (C_n - C_a)$

$$1/S_t = 1/S_n + 1/S_f - 1/(S_n S_f) \approx 1/S_n + 1/S_f \quad (8)$$

Clearly, the total dilution is less than either the near or the far field dilution. If the two dilutions have different magnitudes, the smaller one controls total dilution. For example, a small far field dilution can limit the maximum total dilution no matter how effective the near field mixing is. Abbessi, O, and Roberts, P.J.W. (2014), "Multiport diffusers for dense discharges", *J. Hydraulic Engrg.* 140(8).

Adams, E.E. (1982), "Dilution analysis for unidirectional diffusers". *J. Hydr. Div. (ASCE)* 108(HY3): 327-342.

Adams, E., Harleman, D. R. F., Jirka, G.H., and Stolzenbach, K.D., (1981) "Heat disposal in the water environment", R. M. Parsons Laboratory, Dept. of Civil Engineering, MIT.

Roberts, J.P. (Chair) and four others (2012). *Management of Brine Discharges to Coastal Waters*,

Appendix I Responses to the External Peer Review of the Proposed Desalination Amendment

Recommendations of a Science Advisory Panel, Report prepared by the Southern California Coastal Water Research Project, Costa Mesa, CA for the State Water Resources Control Board, Technical Report 694, March 2012

RESPONSE TO EEA6

Agree. However, for the development of the discharge-related requirements in the proposed Desalination Amendment, since discharges will be to ocean waters, the plume will be under constant influence of currents. Consequently, the plume would be transported away from the point of discharge preventing the potential for static buildup of the plume. Chapter III.L.4 of the proposed Desalination Amendment includes monitoring requirements to ensure that the plume is not building up or pooling on the seafloor resulting in negative effects on beneficial uses.

Conclusion 5: The Area Production Foregone (APF) method using an Empirical Transport Model (ETM) can effectively calculate the mitigation area for a facility's intakes.

COMMENT EEA7

The Area Production Foregone (APF) method is used to determine (the area of) an appropriate project, such as wetland restoration, that would offset the entrainment losses caused by intake water at a power plant or desalination plant. This calculation relies on an Empirical Transport Model (ETM) to estimate the portion of a population lost to entrainment in comparison to the overall population in the water body affected by the cooling water intake (source water body, SWB). This is typically done using target species, with the results extrapolated to other species (Steinbeck, et al., 2007).

Clearly this is only approximate, because it is assumed that populations are uniform over the SWB, and that conditions are simple, e.g., closed (no current) or open (with uniform ambient current). Raimondi (2011) also discusses the impact on APF of statistical error and sample size. While measuring or calculating the rate of larval entrainment is relatively easy, determining where the entrained larvae come from is more difficult, and assuming the SWB is either still or flowing uniformly, is clearly approximate. A more accurate, though burdensome, approach would be to simulate the transport of representative larvae, including their advection, diffusion, and behavior (e.g., vertical migration, natural die-off) with a Lagrangian transport model driven by a 3D circulation field. Recognizing that this is not always feasible, approximate solutions are required and the APF/ETM is a reasonable approach. *Thus I am generally supportive of this conclusion.*

Raimondi, P. (2011) "Variation in entrainment impact estimations based on different measures of acceptable uncertainty". California Energy Commission report CEC-500-2011-020, August 2011.

Steinbeck, J., Hedgepeth, J., Raimondi, P., Cailliet, G. and Mayer, D. (2007), "Assessing power plant cooling water system impacts", California Energy Commission report CEC-700-2007-010.

RESPONSE TO EEA7

Comment noted. There are benefits and drawbacks associated with using any model. However, for the reasons stated in section 8.5.1.1 of the Staff Report with SED, the proposed Desalination Amendment requires the use of the ETM/APF approach.

Appendix I Responses to the External Peer Review of the Proposed Desalination Amendment

Since research is always progressing, there will always be improvements in data acquisition that could be used to further enhance the ETM/APF method. The State Water Board must review and update the Ocean Plan periodically. The approach proposed in the Desalination Amendment, if adopted, will be evaluated and updated in the future as necessary.

4. Bronwyn Gillanders, Ph.D. (BG)

I have reviewed the Water Quality Control Plan for ocean waters of California along with the associated Draft Staff Report (and other documents as necessary) focusing particularly on the proposed amendments in relation to control of the intake of seawater for desalination facilities. Overall, I believe that the best available scientific information has been used to inform the proposed amendment. Where information was lacking, a number of studies have been undertaken. There have also been several reviews of available information that have helped inform the proposed amendments. In addition, I was impressed that consideration had been given to cumulative effects on marine life from past, present and reasonably foreseeable future activities. Potential cumulative impacts are not always addressed. Below are my comments in relation to the specific conclusions that constitute the scientific basis of the proposed regulatory action.

COMMENT BG1

A receiving water salinity limit of two parts per thousand (ppt) above natural background salinity is protective of marine communities and beneficial uses.

The impacts of salinity on marine organisms are species dependent but as indicated in the Staff report marine organisms generally start to show signs of stress when salinity is increased by 2-3 ppt. An exception may be seagrasses which are more sensitive. Most of the studies have focused on potential lethal effects and there are very few investigations of sublethal effects. The lethal effects of brine on marine environments can be minimal if disposal is properly undertaken and managed as dilution can be rapid in a suitable environment. Overall, a water salinity limit of 2 ppt should provide adequate protection of marine environments in terms of lethal effects. The key thing to consider is likely the need for accurate calibration of salinity testing equipment and verification against standards to ensure that any salinity measurements are accurate and capable of detecting a 2 ppt change.

RESPONSE TO BG1

Comment noted. The proposed Desalination Amendment requires that salinity be measured using a standard method (e.g. EPA 160.1), and following standard quality assurance/quality control procedures that include, but are not limited to, replication of data, and equipment calibration.

COMMENT BG2

A subsurface seawater intake will minimize impingement and entrainment of marine life.

There is clear scientific evidence to suggest that subsurface intakes will minimise impingement and entrainment of marine organisms since they generally collect water through sand sediment. However, subsurface intakes may not be able to be used in all locations therefore knowledge of the local geologic conditions is required. The proposed amendments have considered this factor and acknowledge that site and facility-specific factors be

evaluated before deciding on the best method of seawater intake.

RESPONSE TO BG2

Comment noted.

COMMENT BG3

A 0.5 mm, 0.75 mm, 1.0 mm, or other slot sized screens installed on surface water intake pipes reduces entrainment.

Various slot sizes are possible for surface water intake pipes and a number of studies have evaluated effectiveness of mesh screens at reducing impingement and entrainment of marine organisms. As indicated in the staff report species morphology needs to be considered-this can likely be modelled and then further investigated empirically. Knowledge of the fish assemblage at the locality of the desalination facility will be critical to assess the efficacy of different slot screen sizes. For surface water intake pipes there is sufficient evidence in the literature to support the use of slot sized screens to reduce entrainment. However, the size of screen (and performance of screens) may need to be considered on a location by location basis. In addition there may be some variation through time due to differences in larval assemblages. These factors have been considered in a number of the reports.

RESPONSE TO BG3

The proposed Desalination Amendment was revised to require no larger than 1.0 mm slot size screens for surface water intakes. The selection of a single screen slot size was consistent with the project goal to provide a uniform statewide approach for minimizing intake and mortality of all forms of marine life and controlling the associated adverse effects of surface water intakes at desalination facilities. Please also see response to comment 15.5 in Appendix H of the Staff Report with SED regarding the selection of screens size.

COMMENT BG4

Multiport diffusers and commingling brine with other effluents can dilute brine discharge and provide protection to aquatic life.

Commingling brine with other waste discharges has been shown to be one of the most effective methods for brine discharge, but as indicated in the report is not always feasible. Of the other methods, to date, discharging brine through multiport diffusers is likely to provide greatest protection to aquatic organisms as background salinity is reached relatively close to the output. Both approaches can dilute brine discharge and have the potential to minimise impacts on marine organisms when properly utilised.

RESPONSE TO BG4

Comment noted.

COMMENT BG5

The Area Production Forgone (APF) method using an Empirical Transport Model (ETM) can effectively calculate the mitigation area for a facility's intakes.

I am not familiar with many of the approaches to mitigating for desalination-related impacts. However, based on my knowledge of fish life history I agree that the Adult Equivalent Loss (AEL) and Fecundity Hindcasting (FH) approaches are likely to be difficult to implement due to

Appendix I Responses to the External Peer Review of the Proposed Desalination Amendment

the lack of information on growth and survivorship of species at different stages of their life history. As such, for many species there would be insufficient data to evaluate AEL or FH approaches. Given that the empirical transport model and area of production forgone method relies on oceanographic and entrainment data it is more easily calculated for estimation of mitigation. Estimates of production forgone are also used in other areas for mitigation and restoration (e.g. oil spills), again supporting their use in desalination.

RESPONSE TO BG5

Comment noted.

I have also briefly addressed the following questions:

COMMENT BG6

In reading the Substitute Environmental Document that also comprises the Staff Report and proposed amendment language, are there any additional scientific findings that are part of the scientific basis of the proposed rule not described above?

The amendments consider the key marine environmental impacts, namely impingement and entrainment of organisms due to intake of water, and the concentrate and chemicals that are discharged to the marine environment as a result of the process. I believe that the key scientific findings have been adequately described.

RESPONSE TO BG6

Comment noted.

COMMENT BG7

Taken as a whole, is the scientific portion of the proposed rule based upon sound scientific knowledge, methods, and practices?

Overall, the scientific section uses sound scientific knowledge, methods and practices. In particular, consideration of potential cumulative impacts of the desalination facility in combination with other anthropogenic factors is important. This will allow effects of multiple desalination plants to be considered as well as the effect of a desalination plant placed nearby other facilities (e.g. power plant, waste water treatment plant etc).

RESPONSE TO BG7

Comment noted.

COMMENT BG8

The proposed amendments take into account best scientific practice but also provide flexibility to meet project goals and minimise marine impacts as much as possible.

RESPONSE TO BG8

Comment noted.

5. Robert W. Howarth, Ph.D. (RWH)

I have carefully read the draft Appendix A of the Desalination Amendment, the draft Staff Report on *Desalination Facility Intakes, Brine Discharges, and the Incorporation Of Other Nonsubstantive Changes*, and several supporting documents including the Roberts et al. (2012) panel report (SCCW report # 694) on *Management of Brine Discharges to Coastal Waters: Recommendations of a Science Advisory Panel*, the Phillips et al. (2012) study on *Hyper-saline Toxicity Thresholds for Nine California Ocean Plan Toxicity Test Protocols*, the Jenkins and Wasyl (2013) report on *Analytic Comparisons of Brine Discharges Strategies Relative to Recommendations of the SWRCB Brine Panel Report*, and the Missimer et al. (2013) paper published in *Desalination*, vol. 322: 37-51. My review focuses on two major conclusions of the Desalination Amendment.

Conclusion #1. “A receiving water salinity limit of two parts per thousand (ppt) above natural background salinity is protective of marine communities and beneficial uses.”

COMMENT RWH1

I do not think the scientific basis is sufficient to conclude that a salinity limit of two ppt is adequately protective. For the most part, a clear effort was made to use the best available science to support the new standards, and a good basis for this is provided by Roberts et al. (2012), Jenkins and Wasyl (2013), and Missimer et al. (2013). However, as noted by Roberts et al. (2012), the available relevant science is very limited, and several major data and knowledge gaps exist. Note that Roberts et al. (2012) emphasized a major limitation of the available science evidence: “a large proportion of the published work is descriptive and provides little quantitative data that can be assessed independently. Many monitoring studies lacked sufficient details of study design and statistical analyses, making interpretation of results difficult.” They called for improved study and monitoring, noting further that “Such studies using robust experimental designs are currently underway in Australia (e.g., Perth and Sydney desalination plants) and are expected to substantially add to our understanding of field effects of desalination concentrate discharge. Detailed results from these studies are not yet available for review.” This statement was written 2.5 years ago. Results may now be available. If so, they clearly would be immensely informative and should form part of the basis for the draft Staff Report and the draft new standards.

RESPONSE TO RWH1

Comment noted. To our knowledge, these studies are still underway. The State Water Board acknowledges the benefits of the research needs and will review and consider new data and information as it becomes available. The California Ocean Plan (Ocean Plan) is periodically reviewed to ensure that the requirements included are protective of beneficial uses. As new data and information are generated, the State Water Board can consider the need to update the requirements related to the discharge of brine waste.

COMMENT RWH2

Several major issues somewhat undercut conclusion #1 as laid out in the draft Staff Report and the new standards. These include: 1) there is an over-reliance on short-term toxicity tests rather than more sensitive longer-term tests; 2) the additives used by desalination plants (and therefore discharged with the brines) are not adequately considered (see Section 3.1, Chemical Additives, in Robertson et al. 2012 for a discussion on this point); and 3) no evidence is provided to support the conclusion that discharge of brines with comingled sewage, agricultural, or

industrial wastes should be the preferred method of disposal, and I am not aware of any scientific evidence indicating this is in fact a desirable approach;

RESPONSE TO RWH2

These general comments are addressed specifically as they are mentioned in the comments below.

Specifically, I recommend:

COMMENT RWH3

- a greater reliance on longer-term chronic toxicity tests in evaluating discharge standards, and the use of tests with actual RO discharge rather than brines made from freezing seawater where the potentially toxic additives used in RO operations are not present; such information is largely lacking now (Roberts et al. 2012), but its development should be explicitly encouraged; further, it should be noted that the current approach is likely to underestimate effects, and so the proposed brine discharge standard of 2 ppt above background salinities (page 40 of the draft Appendix A of the Desalination Amendment) may not be protective enough; a standard of 1 ppt should be considered, as is used by many agencies in Australia and Japan;

RESPONSE TO RWH3

The receiving water limitation for salinity was based on the best available science, but we agree that more studies should be completed to evaluate chronic exposure to desalination discharges. The proposed Desalination Amendment includes a requirement to establish baseline biological conditions at the proposed discharge location and at a reference location. These data will provide information regarding the long-term effects of the discharge on the marine environment. The regional water board can use the data to evaluate if there are negative effects on beneficial uses resulting from the discharge, and update a facility's NPDES permit accordingly.

COMMENT RWH4

- consideration of a requirement that the chemical additives used by desalination plants be publicly disclosed (according to Roberts et al. 2012, this is not currently the case, as proprietary business claims keep the list of additives a secret); the draft Appendix A of the Desalination Amendment is silent on this point;

RESPONSE TO RWH4

The regional water boards address chemical additives used by desalination facilities in facility-specific NPDES permits. Since the use of these chemicals is highly variable, the regional water boards will continue to regulate chemical additives such as antiscalants, biocides, and cleaning-in-place liquids on a case-by case basis. For more information, please see section 8.8 of the Staff Report with SED.

COMMENT RWH5

- toxic substances, including those that are added by operators but also others such as copper which are known to be release from desalination plants and may simply result from leaching of pipes and filters, should be explicitly considered in risk assessment of discharges, and monitored appropriately; the draft Appendix A of the Desalination Amendment is also silent on this point;

RESPONSE TO RWH5

The scope of the proposed Desalination Amendment addresses salinity-related toxicity. There may be other alterations from desalination discharges relative to normal seawater. As described in response to comment RWH4, the regional water boards will continue to regulate antiscalants, biocides, and cleaning in place liquids on a case-by-case basis.

Even though the scope of the proposed Desalination Amendment is limited to salinity-related toxicity, all other applicable portions of the Ocean Plan will apply to discharges from desalination facilities, including copper regulations. For those chemicals or elements that might not appear in Table 1 of the Ocean Plan, Whole Effluent Toxicity (WET) testing and the toxicity objectives are relied upon to address the effects of mixtures and unknown or unregulated constituents in the effluent. WET testing is also beneficial for identifying toxicity of pollutants for which a numeric objective does not exist. Receiving water monitoring of water quality and biota is used in conjunction with narrative and numeric objectives to ensure that beneficial uses of the receiving water are not degraded by pollutants in the discharge.

COMMENT RWH6

- consideration of requirements that would prohibit the use of some chemical additives (such as chlorine), and requirement of environmentally preferred alternatives (such as perhaps ozone); the draft Appendix A of the Desalination Amendment is silent on this as well;

RESPONSE TO RWH6

Please see response to RWH13 below.

COMMENT RWH7

- greater caution in urging the comingling of brine with sewage, agricultural, and industrial wastes as the preferred method of disposal, as on page 34 of the current draft Appendix A of the Desalination Amendment; there is no available science to conclude that this is in fact an environmentally safe alternative.

RESPONSE TO RWH7

Please see response to comment LAL14 in the Lisa A. Levin Peer Review.

Specific comments on the draft Staff Report regarding conclusion #1:

COMMENT RWH8

Page 13, section 2.2: the report refers to the Phillips et al. (2012) study and states that effects were found at salinities just 2 to 4 ppt above ambient. While this is true, it is perhaps misleading. Phillips et al. (2012) themselves state “The whole effluent toxicity (WET) protocols used in the current research were designed to provide short-term indications of chronic toxicity. Because there is some concern over the chronic effects of brine effluent on marine receiving systems, longer-term chronic toxicity studies should be conducted to confirm the WET protocols are adequately protective of ocean receiving systems impacted by hypersalinity.” I believe it likely that appropriate longer-term chronic toxicity may show effects at lower salinities. Further, as noted by Roberts et al. (2012), most of the experiments in the Phillips et al. (2012) study were with brine created by freezing seawater, and not actual brines from RO facilities, where the addition of biocides, etc., seem likely to increase the toxicity of the effluent.

RESPONSE TO RWH8

Please see response to comments RWH3 and RWH5.

COMMENT RWH9

Page 62, section 8.4.5: the report defines sensitive species as “organisms that can only survive within a narrow range of environmental conditions.” I urge that a broader definition be used, one that would include species that are particularly vulnerable to anthropogenic stresses, such as from toxic substances, whether or not they have a narrow environmental range for survival.

RESPONSE TO RWH9

The definition of sensitive species was expanded on in section 8.4.5 of the Staff Report

with SED and now states,

“Sensitive species are organisms that can only survive within a narrow range of environmental conditions, are sensitive to anthropogenic stresses, or are in need of special protection. CDFW maintains the California Natural Diversity Database (<http://www.dfg.ca.gov/biogeodata/cnddb/>) that “provide[s] the most current information available on the state’s most imperiled elements of natural diversity and to provide tools to analyze these data.” (CDFW 2015) In January 2015, CDFW released a list of “special animals” that they determined are the species most at risk or most in need of conservation efforts. This list includes some marine species and can be used in conjunction with the California Natural Diversity Database to identify sensitive species. There may be sensitive species in a region that are not included on the CDFW list or in the California Natural Diversity Database. For example, the California Natural Diversity Database includes crustaceans and mollusks on their “Special Status Invertebrate Species Accounts,” but does not include any echinoderms (<http://www.dfg.ca.gov/biogeodata/cnddb/invertebrates.asp>).”

COMMENT RWH10

Page 64, option 3: the report states “Desalination facilities could be sited at locations where subsurface intakes are infeasible as long as the regional water board determines it is otherwise the best site and in combination with the best design, technology and mitigation measures results in the least amount of marine life intake and mortality.” Insufficient guidance is given as to how the regional water board would make such a determination in a scientifically defensible manner. Since subsurface intakes are clearly the best approach, again, why not simply require that desalination plants be built only where subsurface intakes are feasible?

RESPONSE TO RWH10

Chapter III.L.2 of the proposed Desalination Amendment provides direction for the regional water boards on how to conduct a 13142.5(b) determination. *This approach was upheld by an appellate court in Surfrider Foundation v. California Regional Water Quality Control Board (2012) 211 Cal.App.4th 557, 576.* The proposed Desalination Amendment also includes a provision allowing the regional water board to require an owner or operator to hire a neutral third party entity to review studies and models and make recommendations to the regional water board. The neutral third party may include experts in the field. Additionally, both the permitting process and the CEQA process for a project are public processes where stakeholders can voice concerns about whether or not the determination is scientifically defensible.

One of the goals of the proposed Desalination Amendment is to support the use of ocean water as a reliable supplement to traditional water supplies while protecting beneficial uses. Water Code section 13142.5(b) requires an owner or operator of a new or expanded facility to use the best available site, design, technology, and mitigation measures feasible to minimize intake and mortality of all forms of marine life. Subsurface intakes represent the best technology for minimizing intake and mortality of all forms of marine life, but they are not available or feasible in all situations. If subsurface intakes are not feasible, an owner or operator may use a screened surface intake. The State Water Board acknowledges that screened surface intakes have significantly higher operational mortality relative to subsurface intakes and that subsurface infiltration galleries may have mortality associated with the construction and maintenance of the intake. The regional water board will first determine if subsurface intakes are feasible and then determine the best available technology alternative that will work in combination with the best available site and best available design alternatives,

resulting in the least amount of intake and mortality of all forms of marine life.

COMMENT RWH11

Page 64, option 3: the report claims “Siting a desalination facility in close proximity to a wastewater dilution source can prevent a facility from discharging toxic concentrations of brine into ocean waters.” This over-states what is known. As Roberts et al. (2012) noted, there has been virtually no study of the effects of co-releasing brines with wastewater sources. Since wastewaters contain toxic materials, this blanket recommendation seems unwise without further study. One explicit conclusion of the Roberts et al. (2012) report states “When concentrate is blended with municipal wastewater, chemical/physical interactions of the concentrate with municipal wastewater constituents may produce toxic effects that cannot be detected using traditional WET test methods.”

RESPONSE TO RWH11

Some large municipal wastewater facilities in southern California are currently diluting brine with wastewater, and the commingled discharge is achieved through diffusers. Reports from regional monitoring studies conducted by the Southern California Coastal Water Research Project indicate there are few environmental impacts that occur in the near coastal marine environment within the southern California Bight. However the regional monitoring studies are not designed to assess impacts associated with specific ocean discharges, rather these studies are intended to assess overall condition of the southern California Bight

(http://ftp.sccwrp.org/pub/download/DOCUMENTS/Bight08_CE_Synthesis_web.pdf)

For some commingled discharges, the salinity of the brine will balance the freshwater nature of the wastewater effluent and the discharge may be near-ambient salinity. As more facilities commingle brine with municipal waste, more data will become available regarding the environmental impacts of commingled discharges.

Chapter III.L.4 of the proposed Desalination Amendment includes ongoing monitoring and reporting requirements that the regional water boards can use to update and revise NPDES permits as needed. Receiving water monitoring of water quality and biota is used in conjunction with narrative and numeric objectives to ensure that beneficial uses of the receiving water are not degraded by pollutants in the discharge.

COMMENT RWH12

Pages 70-71, section 8.5.1.2: the report discusses the toxicity of brine, but does not state that toxic materials such as biocides used by desalinization plants are part of the brine discharge. This is an important point, and unfortunately very little is known about how this affects the overall toxicity of brine discharges (a point highlighted by Roberts et al. 2012).

RESPONSE TO RWH12

Please see section 8.8 of the Staff Report with SED.

COMMENT RWH13

Page 83, section 8.6.1: here, the report brings up the problems with relying on only short-term toxicity tests and the need to fully consider the toxic materials used by desalinization plants: “Most laboratory studies have focused on short-term chronic salinity toxicity associated with Whole Effluent Toxicity testing (WET), for which there is limited information on sub-lethal endpoints associated with reproduction, endocrine disruption, development, and behavior of benthic invertebrates and vertebrates. Additionally, existing WET studies have focused on the salinity of brine discharges, but have not addressed acute and chronic effects from different types of concentrates and mixtures of membrane treatment chemicals (antiscalants) associated with RO. (Roberts et al. 2012; Phillips et al. 2012) Antiscalants are typically used in desalinating seawater; however, chlorine or other chemicals may also be used at facilities to reduce

biofouling (Roberts et al. 2012).” These are critically important points that need to much more fully inform the entire draft Staff Report, and the resulting recommendations. For instance, why allow the use of chlorine? Why not instead require the use of ozone, as is commonly done for many publicly owned sewage treatment plants because the discharge effluent is far less toxic?

RESPONSE TO RWH13

Please see response to comment RWH3 regarding the need for toxicity testing within longer durations, response to comment LAL6 in the Lisa A. Levin Peer Review regarding mixtures of chemicals, and section 8.8 of the Staff Report with SED regarding antiscalants, biocides, and cleaning in place liquids. Table 1: Water Quality Objectives of the Ocean Plan includes limiting concentrations for total residual chlorine (instantaneous maximum- 60 µg/L, a daily maximum- 8 µg/L, and a 6-month median 2 µg/L) that are considered to be adequately protective of beneficial uses. If an owner or operator uses chlorine in their process, the discharge must still meet the total residual chlorine requirements. The regional water boards can address facility-specific issues related to water quality in the individual NPDES permits.

COMMENT RWH14

Page 94, section 8.7.1: the report states “The Panel reviewed scientific literature that addressed impacts of elevated salinity on marine organisms and found that most marine organisms started to show signs of stress when salinity was elevated by 2 to 3 ppt....”, referring to the Roberts et al. (2012) report. This statement is true, but perhaps misleading since Roberts et al. (2012) also noted that this does not account well for the toxic substances used by desalination plants, nor for the inherent insensitivity of short-term toxicity testing (a conclusion also of the Phillips et al. 2012 study). Table 2.1 in the Roberts et al. (2012) report shows that several authorities in Australia and Japan have limited brine discharges to an increase of 1 ppt. This should be explicitly acknowledged by the staff report.

RESPONSE TO RWH14

A paragraph was added to section 8.7.1 of the Staff Report with SED to discuss Table 2.1 from Roberts et al. 2012 and mention that the most conservative regulations for salinity are for facilities in Australia and Japan. In addition to the requirement of demonstrating compliance with the receiving water limitation for salinity, an owner or operator is required to establish baseline biological conditions at the proposed discharge location and at a reference location. These data will provide information regarding the long-term effects of the discharge on the marine environment. The regional water board can use the data to evaluate if there are negative effects on beneficial uses resulting from the discharge and update a facility’s NPDES permit accordingly.

COMMENT RWH15

Page 95, section 8.7.1: the report states “The Science Advisory Panel recommended that salinity vary by no more than five percent at the edge of the zone of initial dilution. For most California coastal waters, this translates to an increase of 1.7 ppt (rounded up, 2 ppt) above ambient background.” To be protective, one should round 1.7 ppt down to 1.0 or 1.5 ppt, and not up to 2 ppt, particularly given the lack of longer-term chronic testing, etc.

RESPONSE TO RWH15

The statement from the Science Advisory Panel (Roberts et al. 2012) is true, but it is based on the average ocean salinity. In places where natural background salinity is lower, the 5 percent limitation is smaller and where natural background salinity is higher, the 5 percent is larger. For example, if natural background salinity is 32, the 5 percent limit would be 1.6 ppt and if natural background salinity is 37, the 5 percent limit would be 1.85 ppt. One of the project goals for the proposed Desalination Amendment is to

provide a consistent statewide approach for protecting water quality, and related beneficial uses of ocean waters. Setting the standard at 5 percent above natural background salinity would not provide a consistent standard since it would vary depending on the natural background salinity at a facility. Setting the standard as 1.5 ppt above natural background salinity may be overly conservative and may also present a disadvantage to facilities located in areas where natural background salinity is higher.

The narrative increase of 2 ppt above background would be protective of sensitive species, while allowing flexibility for fluctuating ocean conditions. Although 2 ppt may allow salinities greater than the LOEC of 35.6 ppt observed for red abalone (Phillips et al. 2012), other studies began to observe ecological impacts when salinity increases were approximately 2 to 3 ppt above background (Roberts et al. 2012). In addition to the requirement of demonstrating compliance with the receiving water limitation for salinity, an owner or operator is required to establish baseline biological conditions at the proposed discharge location and at a reference location. These data will provide information regarding the long-term effects of the discharge on the marine environment. The regional water board can use the data to evaluate if there are negative effects on beneficial uses resulting from the discharge and update a facility's NPDES permit accordingly.

COMMENT RWH16

Page 95, section 8.7.1: the report states “The Science Advisory Panel further recommended that the salinity objective should be based on the most conservative species. The reports by Phillips et al. (2012) and Roberts et al. (2012) provide the basis to develop a receiving water limit for California’s ocean waters. The Granite Canyon report showed that red abalone was most sensitive to elevated salinity, with an LOEC at 35.6 ppt. Since salinity toxicity studies were not done for all organisms in the California marine environment, the 2 ppt limit may be overly conservative for some species, but not conservative enough for others. However, the majority of the studies on elevated salinity showed that effects were not seen below 2 to 3 ppt above natural salinity (Roberts et al. 2012).” This does not acknowledge the caveat in the Phillips et al. (2012) study that the short-term toxicity testing may not be as sensitive as longer-term testing (see my comment above regarding page 13), nor the problem that the Phillips et al. (2012) experiments primarily used brine created by freezing seawater rather than RO effluent, where added biocides, etc., would contribute to the toxicity (see my comment above regarding pages 70-71).

RESPONSE TO RWH16

Please see responses to comments RWH3 and RWH4.

COMMENT RWH17

Page 108, section 8.7.6: the report states “Staff recommends a combination of Option 4 and Option 6. The Ocean Plan should establish a narrative receiving water limit for salinity of 2 ppt above natural background, applied at a distance no greater than 100 meters from the point of discharge.” For the reasons I lay out above, 2 ppt may not be protective enough. The science is simple too uncertain, and has too many gaps, to reach this conclusion. A safer way forward would be to use the 1 ppt standard employed by many agencies in Australia and Japan, and the use high-quality monitoring to ensure that even this lower level is protective enough.

RESPONSE TO RWH17

Please see response to comment RWH15.

Conclusion #2. A subsurface seawater intake will minimize impingement and entrainment of marine life.

COMMENT RWH18

Conclusion #2 is very strongly supported by the scientific evidence, and the draft Staff Report does an excellent job of summarizing this science. However, despite this clear and strong evidence that the use of subsurface intakes are far less damaging ecologically than are surface intakes, the draft new standards allow surface intakes at the discretion of regional water boards. In light of these deficiencies, I am not convinced the new draft standards are sufficiently protective.

I recommend:

- a requirement that only subsurface intakes be used as sources of seawater, since the available science as presented in the draft Staff Report, Roberts et al. (2012), and Missimer et al. (2013) clearly indicates this is far more protective than the use of surface intakes; the draft Appendix A of the Desalination Amendment gives regional water boards the ability to allow surface intakes (pages 32 through 34)

RESPONSE TO RWH18

Comment noted. Please see response to comment RWH10.

Specific comments on the draft Staff Report regarding conclusion #:

COMMENT RWH19

Page 58, section 8.3.5: I disagree with the staff recommendation that surface intake of seawater should be allowed “if subsurface intakes are shown to be infeasible.” The preceding 14 pages of the draft Staff Report do an excellent job of outlining why subsurface intakes are far preferable from an environmental standpoint, as does the Roberts et al. (2012) report and the Missimer et al. (2013) paper. Option 2 is strongly supported by the available science, and the available science indicates that any use of surface intakes is very likely to increase ecological damage, both from entrainment and impingement and from the need to use more chemical additives which are then discharged with the brine effluent. Further, the draft Staff Report gives no guidance as to how to determine where subsurface intakes may be “infeasible.” I recommend that new desalination plants only be allowed where subsurface intakes can be used (or where desalination plants are co-located with once-through electric power generating facilities, as discussed on page 63).

RESPONSE TO RWH19

Please see response to comment RWH10.

COMMENT RWH20

Page 63, option 2: the report states “Option 2 would be environmentally protective but may be overly restrictive and could prevent some communities from being able to use desalination to augment their water supply. Subsurface intakes are not feasible at all locations, and there are only 13 power plants operating in California, including Diablo Canyon Nuclear Power Plant. “This presupposes that siting a desalination plant be determined by the wish of individual communities to have a plant in their own jurisdiction, rather than based on minimizing environmental harm. Why not allow desalination plants only in sites where ecological damage is minimal, with subsurface intakes required and brine discharges only into ecologically insensitive areas? Communities that do not have these attributes within their jurisdiction could ship in freshwater from other facilities (California has a long tradition of shipping water over long distances, when deemed necessary).

RESPONSE TO RWH20

Local water supply agencies have the authority and discretion whether to develop

seawater desalination facilities in their portfolio. A goal of the proposed Desalination Amendment is to support the use of ocean water as a reliable supplement to traditional water supplies while protecting beneficial uses. Desalination is another water supply option that can be used in conjunction with other water supplies to ensure areas can meet their water demands. The proposed Desalination Amendment would apply conditions to those water providers that elect to utilize desalination to increase potable water supplies. It is up to the water providers to evaluate various supply options and costs of each to make informed decisions about future supplies. In some cases, it may be advantageous to ship the water from one area to another. However, the benefits would have to be assessed because there is still the potential for environmental effects associated with moving water (e.g. greenhouse gas emissions, construction of infrastructure).

To ensure that subsurface intakes are used to the extent feasible, the proposed Desalination Amendment includes several provisions to ensure the water is needed and that the identified need cannot be arbitrarily inflated to preclude the use of subsurface intakes. For example, chapter III.L.2.b.(2) of the proposed Desalination Amendment requires consideration of the identified need for desalinated water identified with applicable adopted county general plans, integrated regional water management plans, or an urban water management plan. Chapter III.L.2.d.(1)(a) of the proposed Desalination Amendment states that a design capacity in excess of the identified need shall not be used by itself to declare subsurface intakes as not feasible.

Selecting water supply alternatives at a local, regional, or statewide level is not the role of the State Water Board. Further, the State Water Board does not intend to prioritize or rank water supply options on a statewide level or limit desalination as an option for some communities.

COMMENT RWH21

Page 65, section 8.5: the report again states “Desalination facilities with appropriately designed subsurface intakes can effectively eliminate impingement and entrainment of marine life, and consequently should not need to mitigate for intake-related mortality. However, subsurface intakes may not always be feasible.” The best available science would dictate the exclusive use of subsurface intakes.

RESPONSE TO RWH21

Please see response to comment RWH10.

6. Nathan Knott, Ph.D. (NK)

Conclusion 1: A receiving water salinity limit of two parts per thousand (ppt) above natural background salinity is protective of marine communities and beneficial uses.

COMMENT NK1

Reviewer Comment

Based on the documents provided for review (Jenkins et al. 2012, Phillips et al. 2012, Jenkins and Wasyl 2013 & the Draft Staff Report) and my knowledge of this research area (Roberts, Johnston & Knott 2010), I believe that a salinity limit of two parts per thousand above natural background salinity would be an appropriate limit to protect the marine communities of California.

The review of desalination and its discharge and the environmental effects provided in Jenkins et al. (2012) and the toxicological study by Phillips et al. (2012) were appropriate, thorough and well carried out.

Jenkins et al. (2012) provided an excellent background to the issues related to desalination and the possible mechanisms available to reduce potential impacts. This review was representative of the current scientific literature on desalination issues and potential effects. The

recommendation from this report of a salinity limit of 2 ppt above background levels¹ is in-line with the research published to date.

It should be noted that Jenkins et al. (2012) indicates that the salinity limit requires a compliance point (or a spatial scale) in order to be useful. Jenkins et al. (2012) suggested that the edge of the mixing zone would be an appropriate regulatory point from which the 2 ppt limit could be assessed. They further suggest that this zone could be set at 100 m from the discharge point and extend through the water column from the sea floor to the surface.

This appears to be acknowledged in the draft amendments (Water Quality Control Plan 2014: Receiving Water Limitation for Salinity).

RESPONSE NK1

Comment noted.

COMMENT NK2

Jenkins et al. (2012) also point out that there are very few (or no) published field studies (i.e. real-world assessments of desalination discharges) that cover sites in Californian or local Californian species. Hence, they indicate that it will be important to carry out monitoring of organisms exposed to the discharge and the water quality in the discharge area. They provide clear guidance on necessary monitoring that should be required to demonstrate that the 2 ppt limit is appropriate in California (e.g. water quality and ecological monitoring).

Outlining the monitoring requirements in greater detail in the amendments would be useful.

RESPONSE NK2

The proposed Desalination Amendment, if adopted, will be inserted into the California Ocean Plan (Ocean Plan), which has Standard Monitoring Procedures (see Appendix III of the Ocean Plan). These existing Ocean Plan provisions will apply to all desalination facilities and chapter III.L.4 of the proposed Desalination Amendment includes the additional monitoring not included in Appendix III of the Ocean Plan. The monitoring requirements will vary depending on whether a facility demonstrates compliance with

the receiving water limitation through monitoring in the receiving water body or whether an owner or operator converts the receiving water limitation to an effluent limitation and monitors salinity at the end of pipe.

COMMENT NK3

Phillips et al. (2012) provided a clear indication of the salinity levels likely to affect the development of a representative cross section of the Californian biological diversity expected to be exposed to desalination discharge. This toxicological study found similar results to previous studies (cited therein) which provide further confidence that the effects and tolerances they found were reliable. The most sensitive taxa, red abalone, showed developmental effects above 0.9-1.6 ppt above background salinity levels (i.e. NOEC-LOEC), while the other sensitive taxa (purple urchin and sand dollar) tended to show developmental effects from 1.5-4.6 ppt and several other species showed effects at much high levels (although measures other than development were assessed with these taxa). Hence, a salinity limit of 2 ppt above natural background salinity would appear to be appropriate to confidently limit the effects of short-term exposure to brine discharges on Californian marine species and is in-line with other salinity studies published worldwide (Roberts et al. 2010).

Phillips et al. (2012) also raised two important points in relation to salinity effects:

- a) that exposure to desalination discharge for some organisms may be chronic within the near and far mixing zones, hence, longer term ecotoxicological tests may be required to assess the potential effects of this kind of chronic exposure;
- b) that desalination discharges have been proposed to be comingled with treatment works effluent and industrial cooling water. They suggest this should require further assessment to evaluate whether elevated salinity may interact with other constituents within the mixtures. Furthermore, I would also suggest that temperature may influence the effects of salinity and that for situations where brine is discharged with cooling water that assessments would be needed to determine whether effects occur at lower salinity levels with increased water temperature.

RESPONSE NK3

The receiving water limitation for salinity in the proposed Desalination Amendment was based on the best available science, but we agree that more studies should be done to evaluate chronic exposure to desalination discharges. The proposed Desalination Amendment includes a requirement to establish baseline biological conditions at the proposed discharge location and at a reference location. These data will provide information regarding the long-term effects of the discharge on the marine environment. The regional water board can use the data to evaluate if there are negative effects on beneficial uses resulting from the discharge and update a facility's NPDES permit accordingly.

Regarding the need for additional studies on commingled effluents, please see responses to comments LAL6 and LAL14 in the Lisa A Levin Peer Review Response to Comments.

COMMENT NK4

Phillips et al. (2012) also point out the need to assess the potential effects of desalination discharges into estuarine systems – especially if this scenario (estuarine discharge) is going to be covered and possibly permitted by the current amendments. This comment is appropriate; however, their tests did cover a range of estuarine species (e.g. bay mussel and mysid shrimp) and species that inhabit estuaries as well as the open coast (e.g. sand dollar

and top smelt). So, to some degree they have provided an initial assessment of this. Nonetheless, Höpner and Windelberg (1996) and Roberts et al. (2010) have indicated that siting is a key factor in relation to desalination discharge effects and that estuarine habitats were generally considered to be inappropriate locations for discharge.

RESPONSE NK4

The proposed Desalination Amendment would be included in the Ocean Plan, which regulates discharges into Ocean Waters. Desalination discharges into estuarine waters are currently regulated on a case-by-case basis by the regional water boards and are out of the scope of the proposed Desalination Amendment. Estuaries are dynamic environments and have many site-specific considerations. Brine discharges into estuaries may be addressed in later amendments to the Enclosed Bays, Estuaries, and Inland Surface Waters Plan.

COMMENT NK5

The Jenkins and Wasyl (2013) study was a useful site specific assessment of potential advantages and disadvantages of discharging desalination effluent using an offshore diffuser system or in-plant dilution (and comingling with cooling waters). Nevertheless, this report provided little to assist in making a determination on the appropriateness of the 2 ppt salinity limit.

RESPONSE NK5

Comment noted.

COMMENT NK6

Beneficial uses have not been defined in the documents provided for review and may be outside my area of expertise, hence, I have not commented on this aspect of the conclusion.

RESPONSE NK6

The definition of beneficial uses is included in chapter I.A of the Ocean Plan and is provided here for your convenience:

“The beneficial uses of the ocean* waters of the State that shall be protected include industrial water supply; water contact and non-contact recreation, including aesthetic enjoyment; navigation; commercial and sport fishing; mariculture*; preservation and enhancement of designated Areas* of Special Biological Significance (ASBS); rare and endangered species; marine habitat; fish migration; fish spawning and shellfish* harvesting.”

Conclusion 2: A subsurface seawater intake will minimize impingement and entrainment of marine life.

COMMENT NK7

Missimer et al. (2013) is the only publication presented for the external review for this conclusion, although there is also some coverage of the grey literature within the Draft Staff Report. Nonetheless, the review provided by Missimer et al. (2013) (published in a peer-reviewed journal) indicates that subsurface intakes have been used to pre-filter and collect water from rivers over many centuries and has also been used more recently to provide clean seawater for desalination plants in many places around the world. Conceptually the system seems feasible and it would appear that the large area that the intakes draw water from should mean that the pressures are probably fairly low – hence, unlikely to draw large animals into the sediments or the system itself (e.g. adult and juvenile fish). Nevertheless, I would like to see more information provided on whether this is the case – presumably no field studies on associated impacts exist. Also, would the intake volumes and rates for desalination systems

be similar to river systems?

Furthermore, Missimer et al. (2013) suggests that far less plankton (e.g. bacteria, algae and larvae) are drawn into the desalination system when using subsurface intake systems. This maybe the case, but it is likely that many micro-organisms (e.g. plankton) are still drawn into the sediments and trapped there. So, it may not be without effect, although it is most likely a smaller effect than in comparison with other intake systems.

Overall this system seems promising, though I feel more targeted research on the ecological implication needs to be carried-out. For example, I would suspect that the drawing of water through sandy sediments would change the infaunal community substantially (e.g. from a deposit feeding dominated community to a suspension feeding dominated community), though this may be an acceptable impact without great consequence on the local ecosystem.

RESPONSE NK7

Please see response to comment LAL9 in the Lisa A. Levin Peer Review Response to Comments..

Conclusion 3: A 0.5 mm, 0.75 mm, 1.0 mm, or other slot sized screens installed on surface water intake pipes reduces entrainment.

COMMENT NK8

I have little direct experience with intake screens, however, conceptually I understand what they attempt to do. The reports provided for review indicate that the use of screens with 0.5 mm slots appear to be appropriate.

RESPONSE NK8

Comment noted. Please see response to comment 15.5 in Appendix H of the Staff Report with SED for why a 1.0 mm screen slot size was selected.

Conclusion 4: Multiport diffusers and commingling brine with other effluents can dilute brine discharge and provide protection to aquatic life.

COMMENT NK9

For multiport diffusers, the first component of this conclusion – that they are capable of diluting brine discharge to a suitable level (e.g. to within 2 ppt of background levels within 100m) – is relatively straightforward and well supported by a range of studies covering modelling data and field observations. For the situation of commingling brine with other effluents it would seem feasible that dilution would occur, but only one example was given in the documents provided (e.g. Jenkins and Wasyl 2013; though no indication was provided on how this was determined). This is not to say that commingling would not reach the dilution standard, but rather that few examples were provided to indicate that this is a suitable or reliable approach. It would appear, therefore, that modelling and field studies would be necessary to demonstrate that this form of discharge can provide comparable levels of protection (e.g. to dilute the discharge to within 2 ppt of background levels within 100m).

RESPONSE NK9

A provision was added to chapter III.L.2.d.(2)(a) of the proposed Desalination Amendment to clarify that there must be a sufficient volume of wastewater to dilute the brine so that the resulting effluent is neutrally or positively buoyant. Jenkins and Wasyl 2013 provides an example of flow augmentation where additional seawater is withdrawn for the specific purpose of diluting brine, which should not be confused with commingling where the dilution water is wastewater. The proposed Desalination Amendment requires an owner or operator to conduct studies that demonstrate if an alternative discharge technology (e.g. flow augmentation) provides comparable levels of protection as commingling if wastewater is available, or multiport diffusers if

wastewater is unavailable. This would include studies demonstrating the alternative discharge method could dilute the brine to 2 ppt or the alternative receiving water limitation above background levels within 100 m of the discharge.

COMMENT NK10

The complicated component of this conclusion is, however, whether these dilution techniques provide protection to aquatic life. My initial understanding of the operation of diffusers (primarily from the Sydney Desalination plant) is that they are designed to rapidly dilute the desalination discharge to within approximately 2 ppt of background levels within approximately 100m. In doing so they limit the size of mixing zone (c.f. low pressure releases; Roberts et al. 2010) and, hence, they limit the area affected ecologically by the discharge (where salinity levels are greater than 2 ppt above background and effects may be observed). Obviously the design aim of the commingled brine would similarly be to minimise the area exposed to desalination discharges greater than 2 ppt above background levels. So, aside from the 100m mixing zone, it would appear reasonable to consider diffusers and possibly commingled brine discharges as “providing protection to aquatic life” in comparison with other discharge strategies which dilute the discharges more slowly and maintain higher salinities over larger areas (Roberts et al. 2010).

RESPONSE NK10

Comment noted. The intent of the proposed Desalination Amendment is to ensure protection of beneficial uses and to minimize the area of impact. Commingling brine with wastewater can significantly reduce or eliminate the area where salinity exceeds toxic levels, and multiport diffusers can achieve dilution within 100 meters of the discharge. Other dilution techniques should also be able to meet these standards if they are considered to be equally protective.

COMMENT NK11

An issue raised in one of the review documents (Jenkins and Wasyl 2013) was the potential for diffusers to create shear forces large enough to kill plankton and fish and that this could lead to substantial levels of mortality around the diffusers. Many of the assertions in Jenkins and Wasyl (2013) and also Tenera (2012) are, however, clearly refuted by Roberts (2013) and I agree with the responses provided in this report (Roberts 2013). In particular, that the plankton and fish mortality associated with the diffusers is of interest, however, its importance seems to be exaggerated in Jenkins and Wasyl (2013). Roberts (2013) explains that the diffusers are likely to cause impacts over a very small area around the jets with plankton only being exposed to this area for 10 - 50 seconds. Hence, they would be likely to have very limited effects on the planktonic assemblage passing near or at the diffusers. Diffusers are used in large desalination plants in Sydney and Perth (Australia; footage of the discharge can be seen at <https://www.youtube.com/watch?v=X3fwQB-TRzE>). It should be possible to assess the potential effects proposed in Tenera (2012) and Jenkins and Wasyl (2013) at these Australian desalination plants, if greater clarity is required on this potential issue. Anecdotal reports of the discharge at the Sydney desalination plant suggest that adult fish routinely move in and around the discharge plumes. It is likely that video of the fish movement and behaviour around the discharges when operating at full capacity may exist and could possibly be available to gain an understanding of the likelihood of effects on fish. It should also be noted that fish should be able to behaviourally modify their exposure to the discharges and I would suspect that adult or juvenile fish would avoid the discharges if the flow speeds were damaging.

RESPONSE NK11

Comment noted.

COMMENT NK12

A second issue highlighted in Tenera (2012) and Jenkins and Wasyl (2013) suggested that the fall of the discharge plume could cause the resuspension of soft sediments on the seafloor and that this could affect the local water clarity or turbidity (Jenkins and Wasyl 2013). It is conceivable that this could happen on soft sediment areas, especially considering that these kinds of effects were observed in the SONGS studies. Again the Sydney and Perth desalination plants could be used to evaluate experimentally whether these kinds of effects would be likely to occur considering the differing designs of the desalination diffusers (i.e. having an angle of 60°) and those used to discharge cooling water from the San Onofre power station (i.e. having an angle of 20°). Roberts and Vetter (2013) provide an overview of several turbidity studies – many of which are laboratory studies. However, the resuspension potential of the discharge plumes covers an extremely complex area of disturbance ecology and an enormous amount of wide ranging research has been carried out in relation turbidity, suspended sediments and sedimentation. A substantial review would be required and should focus on algae as well as invertebrates and vertebrates to provide an indication of the potential effects. Nevertheless, the impacts related to resuspension would be difficult to predict from such a review and I would expect that further research, specifically field studies, would be necessary considering the demonstrated vulnerability of Californian kelp to discharges observed in the SONGS studies. Similarly, the effects of the downward fall of the plume (in the mixing zone) could affect the settlement of larvae and algal propagules on rocky reefs and this should also be assessed and considered.

RESPONSE NK12

Chapter III.L.2.c.(5) of the proposed Desalination Amendment includes a provision to design the outfall structure to minimize the suspension of benthic sediments. The height and angle of the diffuser nozzles can influence the velocity of the plume and turbulent eddies that could suspend benthic sediments. As the comment mentions, siting the diffuser should also be considered. For example, the diffuser could be sited in an area with larger grain sizes to reduce the probability of suspension of benthic sediment. It is highly unlikely that any of the desalination facilities will result in the same turbidity issues that occurred at SONGS because the SONGS facility was discharging nearly a billion gallons per day and even the largest desalination facility will be at least an order of magnitude smaller than that. Diffusers are used at almost all of the major ocean outfalls for wastewater treatment plants in California. Some of these municipal wastewater discharges can be 350 MGD during peak wet weather conditions. The Ocean Plan includes effluent limitations for turbidity, which are included in NPDES permits for all ocean dischargers. However, the NPDES permits do not address the re-suspension of benthic sediments from these discharges because it is assumed the impacts are relatively insignificant. Discharges from even the largest proposed desalination facility in California would be less than 150 MGD. Even though the impacts from the suspension of benthic sediments from diffusers associated with brine discharges will likely be insignificant, there are monitoring requirements in chapter III.L.4 of the proposed Desalination Amendment that include assessment of impacts to marine life including benthic communities. This could include monitoring of receiving waters for any turbidity-related impacts if the regional water board determines that is necessary.

COMMENT NK13

A third issue that I raised earlier (in relation to Conclusion 1) is the potential for interactions or synergistic effects between salinity, temperature and other constituents of comingled effluents. If comingled brines are to be the preferred approach to discharging desalination brine (see draft amendments) then I believe a strong understanding of any of these potential interactions should be well understood.

RESPONSE NK13

Please see responses to comments LAL6 and LAL14 in the Lisa A. Levin Peer Review Response to Comments.

Conclusion 5: The Area Production Forgone (APF) method using an Empirical Transport Model (ETM) can effectively calculate the mitigation area for a facility's intakes.

COMMENT NK14

This is a complex issue and the approach stated by Raimondi (2013) appears to be reasonable and workable. It has a reasonably long history in California in relation to cooling water mitigation (Raimondi 2013), so it seems justifiable to use it in a desalination context. Examples of mitigation are provided, however, most of these are for wetlands. It is seemingly less clear how mitigation would operate for the open coast, though one example of the creation of an artificial reef is given and other potential mitigation measures are mentioned. I do not, however, agree that the ubiquity of soft sediment habitats (and overlying water) on the open coast should be used as a reason not to carry out mitigation actions in this habitat. Possible mitigation actions could be funding research to (1) find out more about the functioning of the soft sediment habitats (and overlying water); (2) what may be lost due to the desalination activities in these areas; and (3) how these losses could be reduced in future. I believe that this would be a better strategy than creating an altogether different habitat as is currently suggested (e.g. a rocky reef or wetland seemingly just because this is possible).

RESPONSE NK14

Mitigation of soft-bottom and open water habitat is often impractical or infeasible and mitigating an alternative habitat can result in an overall beneficial mitigation project. Please see section 8.5 of the Staff Report with SED for more on out-of-kind mitigation for soft-bottom and open water habitats. Research plays an important role in understanding impacts of desalination facilities and ensuring water quality plans are protective of beneficial uses. However, putting mitigation funding towards research would not replace lost productivity and would not fully mitigate for impacts.

COMMENT NK15

I also believe the arguments made in Foster et al. (2012) and Foster et al. (2013) in regards to AFP being a better approach is appropriate. This is primarily because it takes into consideration all of organisms impacted by entrainment and impingement (and possibly discharge effects) and not just a select group such as fishes (e.g. EPRI 2004).

RESPONSE NK15

Comment noted.

Additional issues: Discharge monitoring & Siting considerations

COMMENT NK16

Despite the substantial knowledge that is currently available and has been reviewed and used to create the draft amendments for the Californian Ocean Plan (Water Quality Control Plan), there is a clear need to determine the actual ecological effects associated with the use of large desalination plants along the Californian coast. While enormous effort can go into preliminary assessments of potential impacts and improving the technological approaches to reduce these impacts, I believe that it will be crucial to carry out field studies to determine whether actual effects do take place or whether these plants operate as they have been designed (for example, to have discharges that are within two parts per thousand of the background salinity levels within 100m). This is clearly recognised in the current draft amendments (see Water Quality Control Plan 2014: Monitoring and Reporting Programs) and in the advisory panel

report for the State Water Resources Control Board (Jenkins et al. 2012). The draft amendments for the Californian Ocean Plan (Water Quality Control Plan) indicate that Before-After-Control-Impact comparisons (e.g. Underwood 1994, Downes et al. 2002) are required to monitor the discharge plume and its potential ecological effects. Jenkins et al. (2012) suggest this monitoring should be carried out: 1) before construction of the plant, 2) after construction but before the plant is operating (so that construction impacts can be determined and to reduce the chances of confounding of desalination effects by any potential construction impacts) and 3) after the plant has been in operation. I would recommend that data from over a 3 year pre-construction stage and a 3 year operating stage be sampled, as well as the construction stage where possible. Importantly, for BACI analyses to be effective and statistically powerful, multiple reference locations need to be sampled (in order to provide a suitable background to compare against). In many cases, 4-10 reference locations are required to achieve a suitable level of statistical power. This power is essential in order to confidently demonstrate that any potential impacts are smaller than those deemed to be acceptable as part of the permitting of the project (Mapstone 1995, Keough and Mapstone 1997). Alternatively, without appropriate levels of statistical power, the assessment can be criticised for not being adequate to detect sizeable impacts and this would compromise the confidence in any such assessment (Mapstone 1995, Keough and Mapstone 1997). Such a scenario should clearly be avoided in order to maintain public support and confidence.

RESPONSE NK16

Agree that data from the pre- and post-construction and operation of desalination facilities in California will continue to fill data gaps and help to characterize impacts of these facilities. While there is a benefit for a 36-month long study prior to construction and ongoing monitoring to assess environmental variability, this study duration may be impractical an excessive for some facilities. Water code section 13142.5(d) states, “Independent baseline studies of the existing marine system should be conducted in the area that could be affected by a new or expanded industrial facility using seawater in advance of the carrying out of the development.” The proposed Desalination Amendment requires that an owner or operator establish baseline biological conditions at the discharge location and at a reference location prior to commencing construction. The duration of the study to establish baseline conditions will be up to the discretion of the regional water boards. Even though no specific study duration is included, the study should at least be 12 months in order to capture seasonal variations at minimum.

COMMENT NK17

A key factor influencing the effects associated with desalination discharges is the discharge environment (Höpner and Windelberg 1996, Roberts et al. 2010). Logically, it appears that the energy and flushing levels of the environment play a significant role in diluting and dispersing the brine. This significance in relation to siting is covered to some degree in the Draft Staff Report and in Jenkins et al. (2012), however, seemingly there is no clear direction provided on high energy coastline being the priority areas for these plants to be sited. And, on the other hand, that low-energy embayments and lagoons should be avoided due to the increased difficulties in achieving appropriate levels of dilution and mixing. A more explicit direction on the kinds of environments where discharges should and should not be permitted would be useful.

RESPONSE NK17

Please see response to comment NK4.

References

Downes, B. J., L. A. Barmuta, P. G. Fairweather, D. P. Faith, M. J. Keough, P. S. Lake, B. D. Mapstone, and G. P. Quinn. 2002. Monitoring ecological impacts: Concepts and practice in flowing

Appendix I Responses to the External Peer Review of the Proposed Desalination Amendment

waters. Cambridge, University Press.

EPRI. 2004. Extrapolating impingement and entrainment losses to Equivalent Adults and Production Foregone. EPRI, Palo Alto, California.

Foster, M. S., G. M. Cailliet, J. Callaway, P. Raimondi, and J. Steinbeck. 2012. Mitigation and Fees for the Intake of Seawater by Desalination and Power Plants (Expert Review Panel II).

Foster, M. S., G. M. Cailliet, J. Callaway, K. M. Vetter, P. Raimondi, and P. J. W. Roberts. 2013. Desalination Plant Entrainment Impacts and Mitigation (Expert Review Panel III).

Höpner, T. and J. Windelberg. 1996. Elements of environmental impact studies on coastal desalination plants. *Desalination* **108**:11-18.

Jenkins, S., J. Paduan, P. Roberts, D. Schlenk, and J. Weis. 2012. Management of brine discharges to coastal waters: recommendations of a science advisory panel. Southern California Coastal Water Research Project, Costa Mesa, California.

Jenkins, S. and J. Wasyl. 2013. Analytic Comparisons of Brine Discharge Strategies Relative to Recommendations of the SWRCB Brine Panel Report: In-Plant Dilution Vs. high Velocity Diffuser Alternatives at the Carlsban Desalination Project. Scott A. Jenkins Consulting, Poway, California.

Keough, M. J. and B. D. Mapstone. 1997. Designing Environmental Monitoring for Pulp Mills in Australia. *Water Science and Technology* **35**:397-404.

Mapstone, B. D. 1995. Scalable decision rules for environmental impact studies: effect size, Type I, and Type II errors. *Ecological Applications* **5**:401-410.

Missimer, T. M., N. Ghaffour, A. H. A. Dehwah, R. Rachman, R. G. Maliva, and G. Amy. 2013. Subsurface intakes for seawater reverse osmosis facilities: Capacity limitation, water quality improvement, and economics. *Desalination* **322**:37-51.

Phillips, B. M., B. S. Anderson, K. Siegler, J. P. Voorhees, S. Katz, L. Jennings, and R. S. Tjeerdema. 2012. Hyper-Salinity Toxicity Thresholds for Nine California Ocean Plan Toxicity Test Protocols.

Raimondi, P. 2013. Review and Responses to Questions Concerning APF and Mitigation Fees [Appendix 4 to Foster et al (2013) ERPIII].

Roberts, D. A., E. L. Johnston, and N. A. Knott. 2010. Impacts of desalination plant discharges on the marine environment: A critical review of published studies. *Water Research* **44**:5117-5128.

Roberts, P. J. W. 2013. Comments on Tenera (2012): "Biological and Oceanographic Factors in Selecting Best Technology Available for Desalination Brine Discharge" and other turbulence issues [Appendix 2 to Foster et al (2013) ERPIII].

Roberts, P. J. W. and K. M. Vetter. 2013. The Effects of Turbulence and Turbidity Due to Brine Diffusers on Larval Mortality: A Review [Appendix 1 to Foster et al (2013) ERPIII].

Tenera. 2012. Biological and Oceanographic Factors in Selecting Best Technology Available for Desalination Brine Discharge. Tenera Environmental, San Luis Obispo.

Underwood, A. J. 1994. On beyond BACI: sampling designs that might reliably detect environmental disturbances. *Ecological Applications* **4**:3-15.

7. Scott A. Socolofsky, Ph.D. (SAS)

Introduction and Scope

This report presents a scientific peer review of a Proposed Amendment to the Water Quality Control Plan for California Ocean Waters to Address Desalination Facility Intakes, Brine Discharges, and to Incorporate other Nonsubstantive Changes (hereafter, the Amendment). My expertise is in Environmental Fluid Mechanics, and this review covers topics of turbulence, entrainment, general hydraulics, outfall design, and mixing zone modeling. As such, the substantive comments of this review focus on the dilution and turbulence aspects of Science Conclusion 4 that “Multiport diffusers and commingling brine with other effluents can dilute brine discharge and provide protection to aquatic life.”

As requested, I have reviewed the complete text of the proposed Amendment, the Draft Staff Report on the Proposed Amendment (the Staff Report in the following), the report of the External Review Panel III (ERP III, Foster et al. 2013), and several of the cited references. As an expert on jets, plumes, and outfall diffusers, I also bring to the review a strong background in the literature on jets and plumes, multiport diffuser design, and the methods commonly used in their analysis.

This review is structured in three parts. In the first part, I address the overall fluid mechanics statements in the proposed Amendment and the specific content of Science Conclusion 4. My overall conclusion expressed in this section is agreement with the fluid mechanics contained in the Amendment and the Staff Report. In the remaining two sections, I address specific aspects of the amendment that would benefit from improved clarity or slight revision. In the second part, General Comments, I discuss common themes or elements that span multiple sections of the proposed Amendment as well as topics that may not have been addressed directly in the Amendment text. The second section, Specific Comments, presents a few detailed observations that pertain to a single phrase, sentence, or paragraph. These are mostly areas where I felt the text was ambiguous or misleading; my comments seek to focus the intent of the Amendment through each of these recommendations.

Science Conclusion 4

As an overall conclusion, I am in agreement with the scientific statements regarding fluid mechanics processes in the proposed Amendment and in the Staff Report regarding Science Conclusion 4. As a fluid mechanics expert, I have limited my review to flow, mixing, and turbulence. Hence, this review does not evaluate the water quality control standard itself or the biology or toxicology behind it. In particular, I agree with the following findings:

- Brine discharge from desalinization plants will normally be negatively buoyant when discharged to the coastal ocean, requiring an outfall design to promote rapid mixing of the brine discharge to achieve the water quality control standard of 2 ppt salinity above background concentration at the end of the regulatory mixing zone.
- Commingling brine discharge with opportunistic effluent from other sources (e.g., cooling water or effluent from wastewater treatment plants) can dilute brine and

reduce its negative buoyancy before release. In the case of wastewater discharge, which is typically close to the density of freshwater, commingled effluent could be positively buoyant at the point of discharge. Positively buoyant discharges would not descend to the sea floor or impact the benthos.

- Multiport diffusers are a common and reliable means to discharge effluent to the coastal ocean.

These facilities have a strong history of use, including for brine discharge. Proper design can easily achieve a 20-fold dilution within the stated regulatory mixing zone requirement of 100 m laterally from the point of discharge.

- High turbulence has been cited as a mechanism for organism mortality in multiport diffusers.

The analysis presented in Foster et al. (2013) is an accurate means to evaluate the eddy sizes and available energy in a jet from a multiport diffuser. Their conclusion that 23% or less of the total entrained volume required to meet the dilution requirements would be subject to high levels of turbulence is a conservative upper bound.

- Flow augmentation also has the potential to achieve the 20-fold dilution required to meet the stated water quality control criteria. Since flow augmentation will not be allowed to be discharged through a diffuser, the intake will have to be 20 times greater than the desired potable water stream in order to achieve the required dilution within the mixing zone.

These conclusions are the main substance of the proposed amendment as it pertains to my expertise, and I agree that they are based on sound science.

General Comments

This section outlines a few topics that span multiple parts of the Amendment or that were not specifically addressed in the amendment text. Following a short discussion of each topic I suggest a few specific parts of the amendment that could be revised to address the general comment.

COMMENT SAS1

Negatively buoyant plumes and anoxia

Paragraph L.2.c.(4) states that an operator or owner must “design the outfall so that discharges do not result in dense negatively-buoyant plumes that result in adverse effects due to elevated salinity or anoxic conditions occurring outside the brine mixing zone.”

Strictly speaking, this goal cannot be achieved for a typical discharge that does not have commingling of fresh wastewater. For a typical brine discharge, the discharge salinity will be about twice ambient salinity, and an infinite dilution would be required to completely remove its elevated salinity. Moreover, the discharge will be negatively buoyant at the diffuser and may exit the mixing zone as a negatively-buoyant plume on the sea floor.

These facts are acknowledged by the ERP III as they write describing Figure 1 on page 1 of their report.

I believe the intent of this paragraph is to require that:

- The region outside the regulatory mixing zone must not have an anoxic region associated with the discharge
- The salinity must be reduced to a maximum of 2 ppt above background before exiting the regulatory mixing zone.

This opening sentence could, thus, be revised to state: “design the outfall so that the diluted plume exiting the mixing zone meets the water quality standard set for salinity and so that anoxic conditions resulting from the discharge do not exist at the sea floor or in the water column outside the mixing zone.” This acknowledges that the discharge may be a negatively-buoyant plume exiting the mixing zone and defines what is meant by “elevated salinity”. It further requires that the region affected by the discharge beyond the mixing zone remain above the anoxic limit.

RESPONSE SAS1

Chapter III.L.2.c of the proposed Desalination Amendment includes considerations for the regional water board when determining the best available design feasible. We agree that the consideration in chapter III.L.2.c.(4) of the proposed Desalination Amendment may not be possible, and that some plumes may be negatively buoyant as they enter the receiving water bodies. However, the intent is that a discharge should be designed to prevent dense negatively-buoyant plumes that result in adverse effects due to elevated salinity or anoxic conditions from occurring outside the brine mixing zone.

COMMENT SAS2

This comment also pertains to the text on p. 73 of the Staff Report where “dense outfalls that cause anoxia” are not permitted. Revise this section to state that anoxic conditions are not permitted in the region influenced by a brine discharge outside of the mixing zone. Allow, however, for the plume to be negatively buoyant from the discharge to the far-field as would be the case for any discharge of elevated salinity (see, again, Figure 1 of the ERP III report).

Several other parts of the Staff Report also refer to “near ambient” salinity, and on page 82, they characterize the discharged plume as non-buoyant outside the regulatory mixing zone. I point out that, without adding water with salinity below that of the intake, a brine discharge will remain with elevated salinity and negative buoyancy until achieving infinite dilution. Water can be added with salinity below that of the intake either through commingling or by discharging the brine in a coastal region with vertical salinity stratification such that upper layers of the water column have salinity below the intake value (see comments in the next section). However, neither of these conditions are required of all plumes; hence, the report should assume the plume may remain negatively buoyant and with elevated salinity (above background, but less than 2 ppt above background) outside the regulatory mixing zone for a long distance into the far field of the plume.

Please see Figure 1 in the ERP III report for an experimental result showing the dense bottom plume exiting the near field. Throughout the ERP III report it is clear that the authors acknowledge that the final stage of the discharge will be a dense plume traveling along the bottom. The goal of the design should be that the dilution is adequate to prevent this plume

from becoming a barrier between the benthos and the upper water column. This is achieved by requiring the plume to remain oxygenated throughout its trajectory.

RESPONSE SAS2

Section 8.5.1.2 of the Staff Report with SED was revised to clarify that the proposed Desalination Amendment requires consideration that the brine discharges should be designed to prevent the formation of dense plumes that result in hypoxia or anoxia when feasible.

We recognize that the plume may remain negatively buoyant and with elevated salinity (above background, but less than 2 ppt above background) outside the regulatory mixing zone for a long distance into the far field of the plume. Any adverse impacts associated with the dense plume that meets the receiving water limitation are addressed through existing provisions in the California Ocean Plan (Ocean Plan). The Ocean Plan includes a narrative objective that prevents degradation of marine communities and as a result, any change to biological communities caused by a brine plume outside the brine mixing zone will represent a violation of this narrative objective. In regards to hypoxia, chapters III.L.2.c (4) and III.L.4.a of the proposed Desalination Amendment were amended to address this comment by adding requirement to consider the effects of hypoxia in the design and to monitor for potential impacts associated with hypoxia. Associated monitoring would consist of dissolved oxygen and benthic community health.

COMMENT SAS3

Recommended revisions to the Amendment:

- **A. L.2.c.(4).** Per the recommended revision stated above, recognize that the plume leaving the mixing zone may be negatively buoyant and of elevated salinity, and specify that anoxic conditions are not allowed in regions affected by the discharge outside the mixing zone.
- **B.** Search the amendment text for “non-buoyant plume” and decide whether there may be an elevated salinity that is nonetheless within the water quality standard. Plumes with elevated salinity would generally be expected to be negatively buoyant.
- **C.** As I read the Amendment, anoxia would be permitted within the mixing zone. If this is the case, no revision is necessary. If not, please clarify in L.2.c.(4) that anoxia is not permitted in any part of the discharge plume.

Recommended revisions to the Staff Report:

- **D.** Revise page 73 as noted above to clarify that a dense plume with elevated salinity is permitted, but that anoxia within the plume is not. Specify whether anoxia is permitted inside the mixing zone.
- **E.** Search the document for “near ambient salinity” and “non-buoyant plume.” Ensure that the text does not imply the discharge plume with have infinite dilution.

RESPONSE SAS3

- A. Please see response to comment SAS1.
- B. The Staff Report with SED was reviewed in consideration of this comment and no changes were required based on the context and use of the term “non-buoyant plume.”
- C. Anoxia would be permitted within the mixing zone as long as the discharge met all other provisions in the Ocean Plan, including acute and chronic toxicity requirements. As stated in response to SAS1, chapter III.L.2.c.(4) is a consideration when determining the best available design feasible.
- D. The Staff Report with SED was clarified based on this recommendation.
- E. The use of “near ambient” in the Staff Report with SED was in all cases used to describe that the brine could be diluted to a salinity close to natural background or “near ambient” salinity. The use of “non-buoyant plume” was reviewed in the Staff Report with SED and some clarifications were made. However, the use of these terms in the Staff Report with SED does not imply that there would be infinite dilution.

COMMENT SAS4

Density Stratification

On a similar topic, the Amendment does not make any mention of vertical variation of ambient salinity or temperature in the water column, either at the intake or the discharge. Vertical variation is commonly termed stratification and results in a stable density profile with heavier water at the bottom and lighter water at the surface.

Stratification can be important for an outfall design for two reasons. First, as the discharge jet entrains ambient water on its ascent, it becomes increasingly less negatively buoyant. In a density stratified ambient, it is possible that the jet could become neutrally buoyant in the water column, forming an intrusion layer suspended between the sea floor and the free surface. In fact, most wastewater treatment plant discharges are designed to do this so that diluted sewage is sequestered below the sea surface. For a brine discharge, this has the advantage of keeping the diluted brine off the sea floor. Second, in the case of significant salinity stratification due to freshwater inputs along the coast, it is possible that a brine jet could mix to a salinity at or below the intake salinity by entrainment of ambient water into the jet. This has the advantage of eliminating the elevated salinity of the discharge.

I acknowledge that density stratification and salinity stratification are quite variable along the coast, and that a brine discharge can be easily designed to meet the Water Quality Control Standards at the end of the mixing zone without taking advantage of the ambient stratification. I would recommend, then, that the amendment acknowledge that impact could be reduced when favorable ambient stratification exists and allow operators to include stratification in their mixing zone modeling when historic data are available to select a typical vertical profile of salinity and temperature.

Recommended revisions to the Amendment:

- L.2.d.(2)(b). Suggest here that ambient stratification could be used to trap and dilute the plume.

Revise text to state “...shall be engineered to maximize dilution, minimize the size of the brine mixing zone, minimize the suspension or benthic sediments,

minimize the contact of the plume with the bottom, and minimize marine life mortality.”

- L.2.e.(1)(b). The modeling study should be allowed to account for vertical variation of salinity and temperature based on analysis of historical data. Add the sentence: “Average vertical variation of salinity and temperature may be assessed from historical profiles when available and included in the mixing zone modeling.”

Recommended revisions to the Staff Report

- Section 8.6.2.2. Add a paragraph summarizing the potential positive benefits of ambient stratification of temperature and salinity. Provide some guidance on whether vertical stratification may be used in mixing zone modeling and how the assumed profiles of temperature and salinity may be obtained (e.g., as time average like natural background salinity or some other approach).

RESPONSE TO SAS4

Maximizing dilution and minimizing the size of the brine mixing zone will achieve the same results as minimizing the contact with the plume bottom. However, language was added to section 8.6.4 (Option 5) in the Staff Report with SED to state that generally, minimizing contact of the plume with the benthic environment is beneficial for aquatic life and benthic communities.

Regarding the second suggested revision, the regional water boards in consultation with the State Water Board have oversight on the application and use of models. The existing language in the proposed Desalination Amendment is broad enough that the average vertical variation of salinity and temperature could be assessed and included in the mixing zone modeling without including the revision. While the inclusion of salinity and temperature may provide a more accurate model, the mixing zone modeling should also be done using the most conservative scenarios to ensure they are adequately protective.

While this language was not included in the proposed Desalination Amendment, it was included in section 8.6.4 (Option 5) of the Staff Report with SED.

The use of ambient stratification of temperature and salinity was mentioned in section 8.6.4 (Option 5) of the Staff Report with SED. More research is needed to develop guidance that would be useful on a statewide level regarding the appropriate use and application of the assumed temperature and salinity profiles can be used in the modeling of the brine mixing zones.

COMMENT SAS5

Background Concentration

Paragraph L.3.b.(2) presents the equation to calculate the allowable salinity of the effluent so that the discharge will meet the water quality control standard of 2 ppt above the natural background at the end of the regulatory mixing zone. The Definition of Terms section of the amendment defines the natural background concentration as a 20-year historical average or an average based on 3 years of intensive monitoring when historical data are not available. As I understand the amendment, this sets the natural background concentration as a constant and does not allow for seasonal variability in the background salinity. Figures 8.5 and 8.6 in the Staff Report show that background salinity at a given site can vary over 2

Appendix I Responses to the External Peer Review of the Proposed Desalination Amendment

ppt over seasonal and annual time scales. By setting the natural background concentration to a constant it would be possible that seawater entering the intake of a desalination plant would already exceed 2 ppt above a constant average background value. Hence, a means to include natural variability is needed.

The definition of the natural background concentration in the Amendment hints that a nearby reference station could be used to provide a variable background concentration against which the 2 ppt above background standard could be applied. There is not much guidance there, and it seems to me that the amendment itself should acknowledge the need for a variable background reference and propose a means to establish its value. Since the intake is required to be designed in a way that it does not take in water from the discharge, the intake salinity would be a reasonable reference value for the background.

Recommended revisions to the Amendment:

- L.3.b.(2)(c). If the intent of the alternative maximum value is to allow for values greater than

2000 mg/l, revise to clarify this. If not, the text is acceptable as it is.
- L.2.b.(2). Add a new section (d) to state how a time-varying value of the natural background concentration could be obtained for the purposes of enforcement.
- NATURAL BACKGROUND SALINITY. Explain in the amendment what the function is of the reference location with similar background salinity that is to be used for comparison in ongoing monitoring of brine discharge. Does this mean that the background value is not a constant in the equation in L.3.b.(2) during enforcement? The Amendment is somewhat vague to my reading as to whether the background value that sets the 2 ppt above background standard is a constant or is allowed to be variable in time during operations.

Recommended revisions to the Staff Report

- Section 8.7.2. Specify whether a time-varying value of the natural background salinity may be used for the purpose of enforcing the 2 ppt above background standard and how that background salinity is to be established.

RESPONSE TO SAS5

The proposed Desalination Amendment was revised to account for seasonal variation in salinity by defining natural background salinity based on a mean monthly average. Using the actual salinity measured at an intake as the natural background salinity does not work for facilities with the intakes located nearby the discharges. In this scenario, the brine discharge could make the intake water saltier and saltier over time but the facility would not be in violation of the receiving water limitation for salinity, even though natural background salinity is increasing over time. It is possible to use the natural background salinity at a reference location; however, there is uncertainty that the reference location is representative of the same discharge conditions at the proposed discharge location. Therefore, the Proposed Desalination Amendment requires the use of natural background salinity data for determining compliance with the receiving water limitation for salinity. Since it is based on a mean monthly average, the equation will be based on the natural background salinity for the month.

Please also see responses to comments 6.9, 15.17, and 13.130 in Appendix H of the Staff Report with SED.

The intent of the alternative receiving water limitation is to allow for values greater than 2.0 ppt above natural background salinity. The alternative receiving water limitation must be met no further than 100 meters horizontally from the seafloor to the sea surface.

The requirement to establish a reference location is standard for NPDES permits. In the proposed Desalination Amendment, the reference will be used as a salinity comparison, but also to monitor for health of the marine community. As stated in section 8.7.2 of the Staff Report with SED, “brine discharges have the potential to alter natural background salinity and elevate salinity to levels beyond the tolerance levels for local species. In some cases, establishing a reference location with similar natural salinity can be helpful in drawing comparisons between pre- and post-discharge conditions.” The Ocean Plan includes a provision that discharges do not result in the degradation of marine communities. The reference locations should be established to help detect any changes to biological communities caused by a brine plume, and outside the brine mixing zone. Any degradation would represent a violation of this narrative objective.

Section 8.7.2 of the Staff Report with SED was revised to clarify that natural background salinity should be based on the mean monthly average and discusses how the mean monthly average should be established.

COMMENT SAS6

Mortality estimates

The ERP III report provides good detail on the estimation of mortality of organisms entrained into multiport diffusers as a result of turbulence in the jet. I am in agreement with the methodology applied by Roberts and Vetter (Appendix 1 of Foster et al. 2013). The Kolmogorov length scale is the correct scale for the fine-scale eddies in a jet. Their estimates of the Kolmogorov length scale use the correct scaling relationships and empirical coefficients. The estimate that 23% of the total entrained volume required to meet the 5% dilution standard could be in a high-turbulence region of the plume is a conservative upper-range estimate. It is likely that less of the total volume would contain lethal levels of turbulence for passive organisms.

Recommended revisions to the Amendment:

- I am in agreement with the amendment

Recommended revisions to the Staff Report:

- I am in agreement with the Staff Report.

RESPONSE TO SAS6

Comment noted.

COMMENT SAS7

Mixing Zone Definition

Page 97 of the Staff Report describes the typical definition of a mixing zone used in the California State water quality standards. The general definition of a mixing zone is the region near a discharge where dilution is allowed to occur and upstream of where a water quality standard is going to be enforced. A regulatory mixing zone is an operational

definition of the extent of this dilution region. In other parts of the water quality code in California, the mixing zone is apparently defined by the dilution and does not have a fixed lateral extent. The proposed amendment for brine discharges uses a different definition, equal to 100 m laterally from the discharge. This definition is a common one, but it is different from other parts of the water quality control code, and it may be advisable to have a consistent definition within the State.

Recommended revisions to the Amendment:

- **BRINE MIXING ZONE.** Consider whether this definition is consistent with mixing zone definitions in other parts of the California water quality code. If not, consider whether to revise to match other definitions.

It also seems that the definition confuses the definition of mixing zone with regulatory mixing zone. This definition states that the mixing zone is the region with salinity more than 2 ppt above background and that the regulatory mixing zone extends to a maximum of 100 m laterally from the discharge point, yet the definition excludes the important distinction “regulatory.” Consider having two definitions, one for mixing zone and one for regulatory mixing zone.

Recommended revisions to the Staff Report

- If the Amendment is modified to match mixing zone definitions elsewhere in the California water code, update the Staff Report to be consistent with the Amendment.

Search “mixing zone.” If the reference is to the region with salinity greater than 2 ppt above background, leave the text as is. If the reference is to a region extending up to 100 m laterally from the discharge, revise the text to read “regulatory mixing zone.”

RESPONSE TO SAS7

The brine mixing zone as used in the proposed Desalination Amendment refers to a regulatory mixing zone. One of the goals of the proposed Desalination Amendment is to provide a consistent statewide approach for protecting water quality and related beneficial uses of ocean waters. For implementation of a regulatory mixing zone, in this case the definition of brine mixing zone, helps to achieve that goal. The use of “mixing zone” was reviewed in the Staff Report with SED and clarifications as to whether the use was regarding a physical zone or a regulators zone were incorporated.

COMMENT SAS8

Area or Volume of Impact Computed for Mitigation

Page 81 of the Staff Report states in the case of a multiport diffuser discharge that the impacted region can be estimated as the area or volume for which the salinity exceeds 2 ppt within the mixing zone. This is ambiguous for two reasons. First, a multiport diffuser jet is a three-dimensional object, so that its areal extent is hard to quantify. Certainly the radius to the point where the salinity is 2 ppt above background can be estimated, and the region inside this radius could be the impacted area. However, this point can occur high in the water column, making a lateral distance ambiguous. Second, the discharge jet is a narrow, boundary layer flow so that the volume contained inside the jet may be quite small. Estimating this volume is straightforward using jet mixing models. The difficulty comes in converting this impacted volume to the necessary mitigation area. All of the mitigation

Appendix I Responses to the External Peer Review of the Proposed Desalination Amendment

requirements are on an acreage-basis. No guidance is provided to convert an impacted volume inside the mixing zone to a required mitigation area.

The Amendment in section L.2.e.(1)(b) states that the area approach is required for estimation of the impacted region. This could be made more precise by requiring that the projected, plan-view area in which salinity exceeds 2 ppt above natural background be used.

Recommended revisions to the Amendment:

- L.2.e.(1)(b). Revise text to refer to the “projected, plan-view area.” Recommended revisions to the Staff Report
- Page 81. Remove text referencing a volume estimate for the impacted region; specify that the lateral distance from the discharge used to estimate impacted area should be a projected, plan-view distance.

RESPONSE TO SAS8

The suggested revisions were not included in the proposed Desalination Amendment or the staff Report with SED because the term “projected, plan-view” is vague and could result in insufficient mitigation.

The proposed Desalination Amendment is one of the first to require assessment of impacts associated with the discharge within the brine mixing zone. The proposed Desalination Amendment allows an owner or operator to assess discharge-related mortality using any acceptable method(s) that has been approved by the regional water board. The method described in section 8.5.1.2 of the Staff Report with SED is an example of how the two-dimensional area can be used to estimate the number of acres required to mitigate to the loss of productivity. In most cases where a discharger is discharging undiluted brine, the area/volume that exceeds 2 ppt above natural background salinity will be higher than the area/volume where shearing-related mortality may occur. The concept of using the two dimensional acreage to assess impacts may be an appropriate estimate of acres of habitat to mitigate. The mitigation requirement may include a requirement to mitigate 10 acres of rocky reef habitat, but even though the mitigation requirement is in acres, the actual habitat has three dimensions. Overall, the goal of the mitigation project is that the productivity lost at a discharge will be balanced by the productivity at a mitigation site. The regional water boards in consultation with the State Water Board will determine the best available mitigation feasible to fully mitigate for impacts associated with a desalination facility.

Detailed Comments

Proposed Water Quality Control Amendment

COMMENT SAS9

- L.2.b.(4). “bathymetry...seafloor topography.” These are the same thing but are listed as different measurements which must be made in a comprehensive list. Later, in paragraph L.2.d.(1)(a)i., the term “benthic topography” is used. Recommend using one term for the bottom topography and using that term throughout.

RESPONSE TO SAS9

Chapter III.L.2.b(5) (formerly (4)) of the proposed Desalination Amendment was revised to

remove the redundant “bathymetric” requirement.

COMMENT SAS10

- L.2.d.(1)(a). “require subsurface intakes unless ... are infeasible.” Recommend to add a statement here why subsurface intakes are required so that there is a relevant benchmark against which to determine if surface intakes are infeasible. For example, L.2.d.(2)(a) states “the preferred technology to minimize intake and mortality of marine life...” [underline added]; hence, the justification is stated with the requirement. L.2.d.(1)(a) could be revised similarly: “to eliminate intake and mortality of marine life, subsurface intakes that use natural filtering of the sediments are required unless...”

RESPONSE TO SAS10

The proposed addition is not required because the entirety of chapter III.L.2 of the proposed Desalination Amendment is to determine the best available site, design, and technology feasible to minimize intake and mortality of all forms of marine life. For more information on why subsurface intakes are the preferred intake technology, please see section 8.3 of the Staff Report with SED.

COMMENT SAS11

- L.2.d.(1)(c)iii. Screens are designed to stop marine life entrainment, but I assume the eggs and larvae and some juvenile fish caught by the screens become impinged, unable to get off of the screens. What are operators required to do with the debris and organisms stopped by the screens? May they dispose of it? In that case, all organisms impinged on the screens will suffer mortality and the screen size need only be large enough to prevent entrainment of mobile organisms capable of not becoming impinged. If impinged organisms cannot be disposed of, should the screens be backwashed? I did not notice any guidance in the Amendment.

RESPONSE TO SAS11

The intake screen requirement is coupled with the requirement that the maximum intake flow velocity be no more than 0.5 ft/s. This intake velocity has been required in U.S. EPA’s Phase I Rule and the State Water Board’s OTC Policy because it has been demonstrated to protect most small fish and all adult fish from impingement. Additionally, intake screens can be designed and oriented so the ambient currents move eggs, larvae, and smaller juveniles up and over a cylindrical wedgewire screen (see Wedgewire Screen sub-heading in section 8.3.1.2.3 of the Staff Report with SED). However, if impingement occurs, chapter III.L.2.e of the proposed Desalination Amendment states that, “The owner or operator shall *fully* [emphasis added] mitigate for all marine life mortality associated with the desalination facility.”

COMMENT SAS12

- L.2.d.(2)(a). Commingling is preferred with wastewater that “would otherwise be discharged to the ocean.” This statement can end here. Adding, “unless the wastewater is of suitable quality and quantity to support domestic or irrigation uses,” is unnecessary. Presumably, if the available wastewater for commingling is of suitable quality, it would not be otherwise discharged to the ocean. It seems logical that commingling should be allowed with any waste stream that “will otherwise be discharged to the ocean.” Some other part of the Control Plan should clarify that wastewater of suitable quality and quantity to support domestic or irrigation uses should never be discharged to the ocean. Also, the next paragraph introduces multiport diffusers, which is a discharge technology. The present paragraph is an effluent technology, but there is no

mention of the type of discharge. I would assume that a commingled flow would also be discharged via multiport diffusers. It seems this paragraph and the next should go together and not be unique from one another.

RESPONSE TO SAS12

Chapter III.L.2.d.(2)(a) of the proposed Desalination Amendment was revised as follows to address the comments above:

(a) *"The preferred technology for minimizing intake and mortality of all forms of marine life* resulting from brine* disposal is to commingle brine* with wastewater (e.g., agricultural, ~~sewage municipal~~, industrial, power plant cooling water, etc.) that would otherwise be discharged to the ocean, ~~unless the wastewater is of suitable quality and quantity to support domestic or irrigation uses.~~ The wastewater must provide adequate dilution to ensure salinity of the commingled discharge is less than or equal to the natural background salinity,* or the commingled discharge shall be discharged through multiport diffusers.* Nothing in this section shall preclude future recycling of the wastewater."*

COMMENT SAS13

- L.2.d.(2)(b). "Multiport diffusers are the next best..." Revise to "Multiport diffusers are the next preferred..." Also, see the comment above for L.2.d.(2)(a). It seems that multiport diffusers are not an alternative to commingling a waste stream; rather, these technologies would likely be used together.

RESPONSE TO SAS13

Please see response to comment SAS12.

COMMENT SAS14

- L.2.d.(2)(c). This sentence is grammatically incorrect. Operators are required to analyze for what? There needs to be an objective function to the analysis. Revise to state "...analyze the brine disposal technology or combination of brine disposal technologies to determine which option best reduces the effects..."

RESPONSE TO SAS14

Chapter III.L.2.d.(2)(c) was deleted from the proposed Desalination Amendment since the requirements are included in chapter III.L.2.d.(2)(c)(formerly chapter III.L.2.d.(2)(d)) for an owner or operator proposing an alternative brine disposal technology.

COMMENT SAS15

- L.2.d.(2)(d). The owner must evaluate all sources of marine mortality, including inside the desalination plant. However, throughout the amendment it is assumed that processes in the plant will kill all organisms entrained through the intake. It seems to me that the operator should be required to assess mortality associated with the intake and the discharge only: any organism entrained through the intake is assumed lost. Rather than requiring the owner to estimate marine life mortality that occurs inside the plant, provide that as an option in the case there is evidence that the mortality is less than 100% and the owner would like to establish that fact.

RESPONSE TO SAS15

Agree. As stated in chapter III.L.2.d.(2)(c) of the propose Desalination Amendment, the baseline assumption is that unless demonstrated otherwise, organisms entrained by flow augmentation are assumed to have a mortality rate of 100 percent. The same assumption would apply to any alternative intake technology. The regional water boards will require an owner or operator demonstrate through studies that mortality of

entrained organisms is less than 100 percent if an owner or operator makes that claim.

COMMENT SAS16

- L.2.d.(2)(d)iii. The operator must estimate mortality inside the desalination plant (e.g., water conveyance, in-plant turbulence or mixing); yet, the amendment already assumes 100% mortality for organisms that pass through the intake. Hence, this paragraph should be revised to “Estimate marine life mortality that occurs as a result of the waste discharge and assume marine life mortality for organisms passing through the intake to be 100% as a result of water conveyance, in-plant turbulence, and osmotic variability unless there is evidence to the contrary.”

RESPONSE TO SAS16

During the State Water Board’s stakeholder outreach process, there have been theoretical systems that may not have 100 percent mortality associated with the entrained organisms. As stated in chapter III.L.2.d.(2)(c) of the proposed Desalination Amendment, the baseline assumption is that unless demonstrated otherwise, organisms entrained by flow augmentation are assumed to have a mortality rate of 100 percent. Chapter III.L.2.d.(2)(c)iii allows an owner or operator the opportunity to demonstrate entrainment mortality is less than 100 percent in their system.

COMMENT SAS17

- L.2.d.(2)(e)i. Operators who choose flow augmentation must use low turbulence intakes (e.g., screw centrifugal pumps or axial flow pumps) and conveyance pipes. However, the ERP III report states that there is no evidence that such pumps 1.) are sub-lethal or 2.) can deliver the required flow volumes. Moreover, in the following paragraph iii, organisms entrained by flow augmentation are assumed to have 100% mortality unless demonstrated otherwise through studies within three years of operation. Hence, at the design and initial permitting stage, 100% mortality inside the plant must be assumed. Owners should have the option to assume 100% mortality and to use the most efficient pumps available.

RESPONSE TO SAS17

Per the requirements in the proposed Desalination Amendment, the regional water boards may only permit alternative intake of discharge technologies such as flow augmentation if the alternative technology is as protective as the standard (e.g. 1.0 mm screens or commingling with wastewater or multiport diffusers). Flow augmentation systems withdraw significant volumes of excess seawater for the specific purpose of diluting brine. The purpose of the low turbulence intake pumps requirement is to minimize marine life mortality in the dilution water. An owner or operator proposing to use flow augmentation must be able to demonstrate that even with the excess volume of seawater withdrawn, the intake and mortality is less than that of commingling with wastewater if wastewater is available, or discharging through multiport diffusers if wastewater is unavailable. Unless demonstrated otherwise, it is assumed there is 100 percent mortality of entrained organisms. To date, there is no evidence supporting flow augmentation systems as equally protective as discharging through multiport diffusers (please see response to comment 15.20 in Appendix H of the Staff Report with SED). However, this provision allows for future technological innovations where the technology is as protective as discharging through multiport diffusers.

COMMENT SAS18

- L.2.d.(2)(e)vi. Why is flow from flow augmentation prohibited from being discharged through a multiport diffuser? Because of high turbulence? Or some other reason? As stated, this seems arbitrary, and the rationale should be given.

RESPONSE TO SAS18

This provision was included with the assumption that there would be adequate dilution resulting in a neutral or positively buoyant plume; and that there were live organisms in the flow augmentation effluent. This provision was written with a system in mind proposed by Poseidon Resources that would use low turbulence intake pumps to intake dilution water containing eggs, larvae, etc. The flow augmentation water would be conveyed and mixed with the raw brine, and then discharged. The theory is that the majority of the organisms would leave the system alive. If it is possible to successfully design this system, discharging effluent with live organisms through multiport diffusers would defeat the purpose of the other components in the system designed to protect the organisms.

COMMENT SAS19

- L.3.b.(2)(c). 2000 mg/l above background is set as the maximum allowable salinity increase allowed at the end of the regulatory mixing zone. Can the alternative value substituted by a facility-specific study be higher than 2000 mg/l? As written, I would say legally it could not be. However, it seems the intent of this section is to permit higher levels. Revise for clarity.

RESPONSE TO SAS19

We assume the commenter is referring to chapter III.L.3.c of the proposed Desalination Amendment that allows an owner or operator to apply for an alternative receiving water limitation for salinity. This section requires an owner or operator to base the alternative on the LOEC for the most sensitive species as determined by WET testing. The alternative value may be higher or lower than 2.0 ppt. If the alternative value is higher, the regional water board can allow a receiving water limitation of that value above natural background salinity to be met no further than 100 meters horizontally from the discharge. The definition of brine mixing zone was also revised to provide clarity.

COMMENT SAS20

- BRINE MIXING ZONE. The definition here is not clear. Various definitions used here include salinity above 2 ppt above background, a lateral distance of 100 m, or a region determined by modeling. For clarity, simply state that the regulatory mixing zone extends to 100 m laterally from the discharge.

RESPONSE TO SAS20

The definition of brine mixing zone was revised to provide clarity. The brine mixing zone is an allocated impact zone where there may be toxic effects on marine life due to elevated salinity. It is also defined as the area where the salinity exceeds 2.0 parts per thousand above natural background salinity, or the concentration of salinity approved as part of an alternative receiving water limitation. The brine mixing zone shall not exceed 100 meters (328 feet) laterally from the points of discharge and throughout the water column.

COMMENT SAS21

- MULTIPOINT DIFFUSERS. These can be used for more than just brine. Revise to remove brine from the definition.

RESPONSE TO SAS21

Comment noted. The second part of the definition of multiport diffusers was revised to apply to chapter III.L of the proposed Desalination Amendment.

COMMENT SAS22

- NATURAL BACKGROUND SALINITY. Is the reference location suggested by this definition an acceptable value of background concentration for the equation in section L.3.b.(2)?

RESPONSE TO SAS22

No. Please see response to comment SAS5.

Staff Report

COMMENT SAS23

- Citation format is unusual. It appears that citations are placed outside the end of the sentence being cited. As in: “concentration found in empirical studies. (citation) New sentence.” I have never seen this format before and find it ambiguous. Does the citation apply to the first sentence in the above example or the new sentence? Citations belong within the sentence being cited: “concentration found in empirical studies (citation).”

RESPONSE TO SAS23

Comment noted. The citation format is unusual for most academic journals. However, the style format for the Staff Report with SED is based on the California Style Manual, Fourth Edition, 2000.

COMMENT SAS24

- P. 65. Bulleted list. Revise “statistical certainty” to “statistical uncertainty.” Statistics are typically used to quantify uncertainty. Unless you sample a whole population, statistics cannot quantify certainty.

RESPONSE TO SAS24

The Staff Report with SED was revised to explain that the approach can be used to add a buffer to mitigation projects to account for statistical uncertainty.

COMMENT SAS25

- P. 92. Discussion of mortality. If 100% of organisms that pass through an intake die, then there is no remaining mortality to quantify inside the plant.

RESPONSE TO SAS25

Please see responses to comments SAS15, SAS16, and SAS 17.